



Integral solutions, powered by DuPont.

For decades, innovative technologies from DuPont have purified water needed to power communities worldwide.

SEE HOW

**Boiling
Water Reactor**



**Pressurized
Water Reactor**



BOILING WATER REACTOR



PRESSURIZED WATER REACTOR

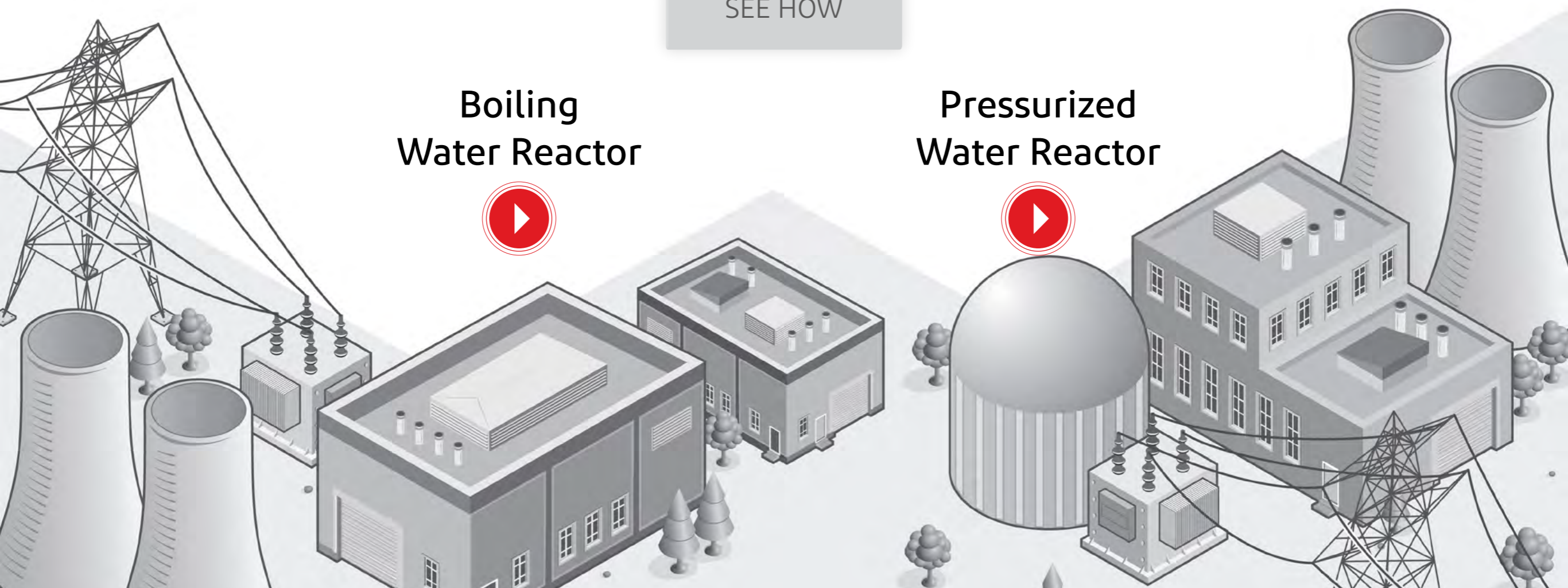



NUCLEAR POWER PLANT WATER TREATMENT

THE CHALLENGE



Today, challenges in generating power are growing along with the demand. More than ever, nuclear power plants need high quality, safe and reliable solutions to meet their water treatment needs, prolonging operational and equipment life and preventing corrosion, maintenance and unscheduled outages.

THE SOLUTION



DuPont is helping to ensure reliable operation and improve worker safety in nuclear power plants of every type. With world-class innovation and quality in water treatment technologies, along with local expertise and global experience, we offer products that can help protect your assets, increase efficiencies and keep your plant running optimally.

We work closely with utilities, service providers and equipment manufacturers to provide integrated solutions in all of the water treatment applications found in boiling and pressurized water reactors.

BACK



The power of water.

For decades, innovative technologies from DuPont have purified water used throughout nuclear power plants.

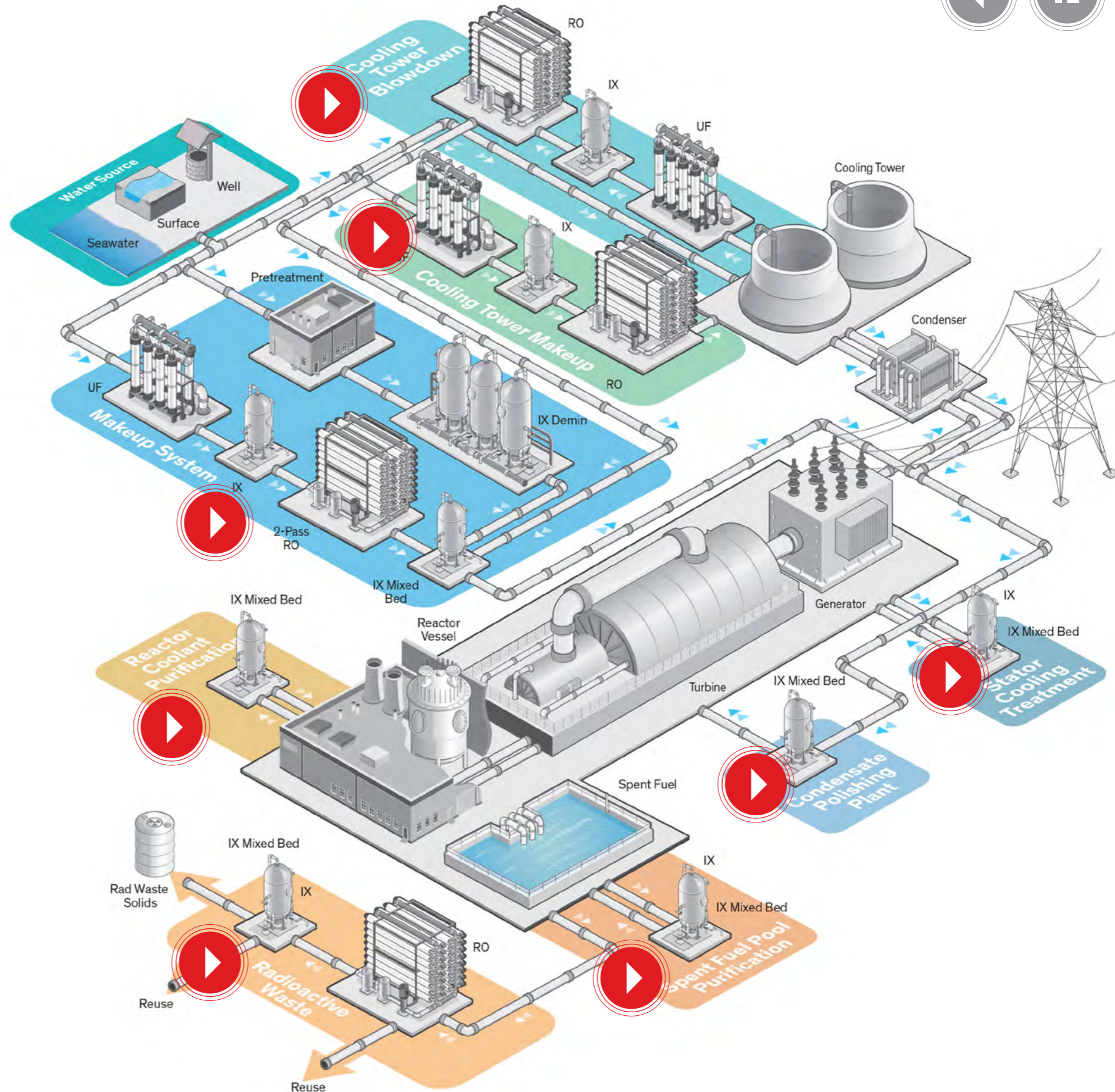



Keep it cool under pressure.

For decades, innovative technologies from DuPont have purified water used throughout nuclear power plants.

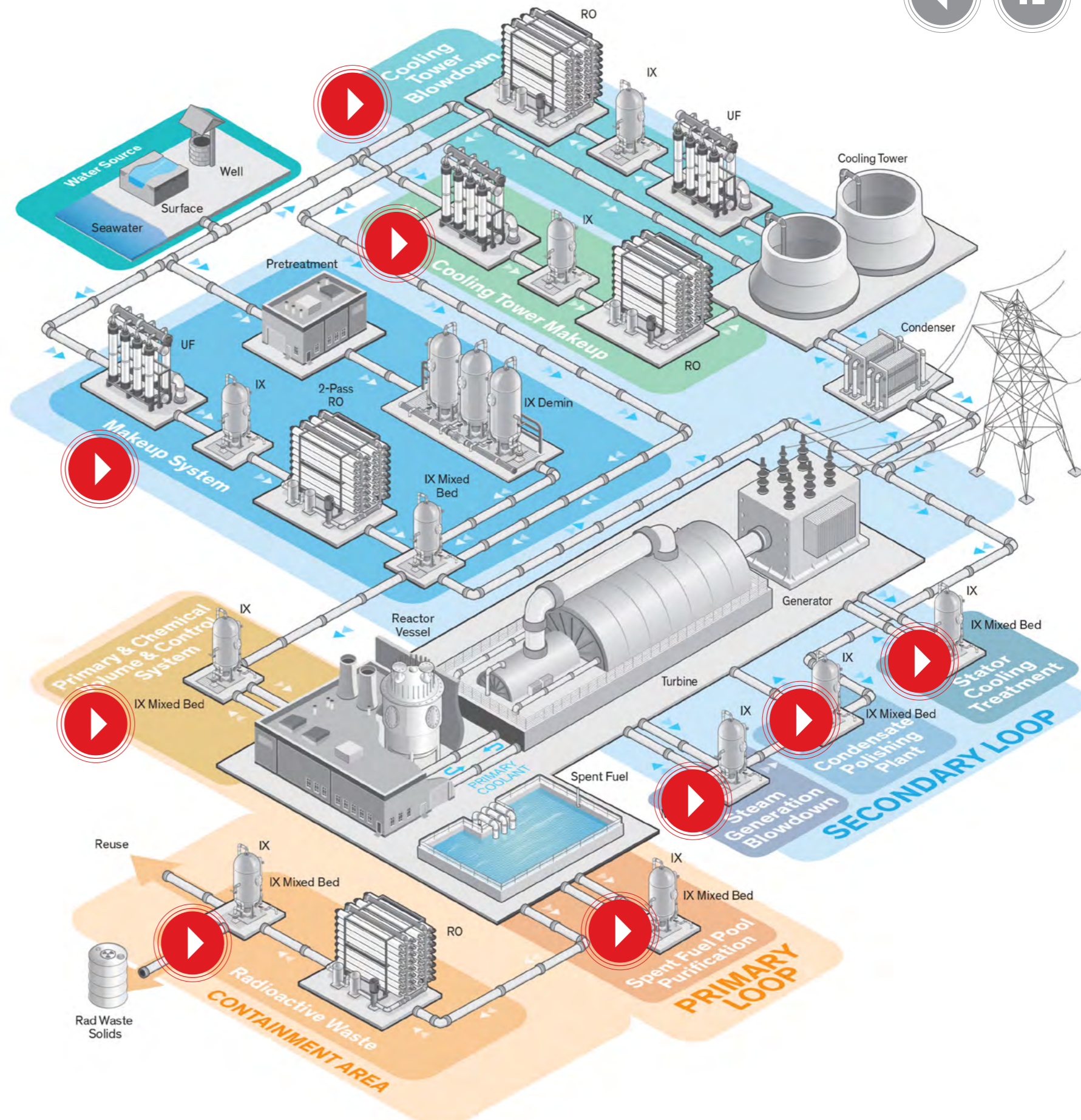



Boiler alert.

Reduce downtime and save money, no matter the water source or pressure requirements.

SEE HOW

COMMON DESIGNS

RECOMMENDED PRODUCTS

Click on **technologies** to better understand their role in makeup water treatment.

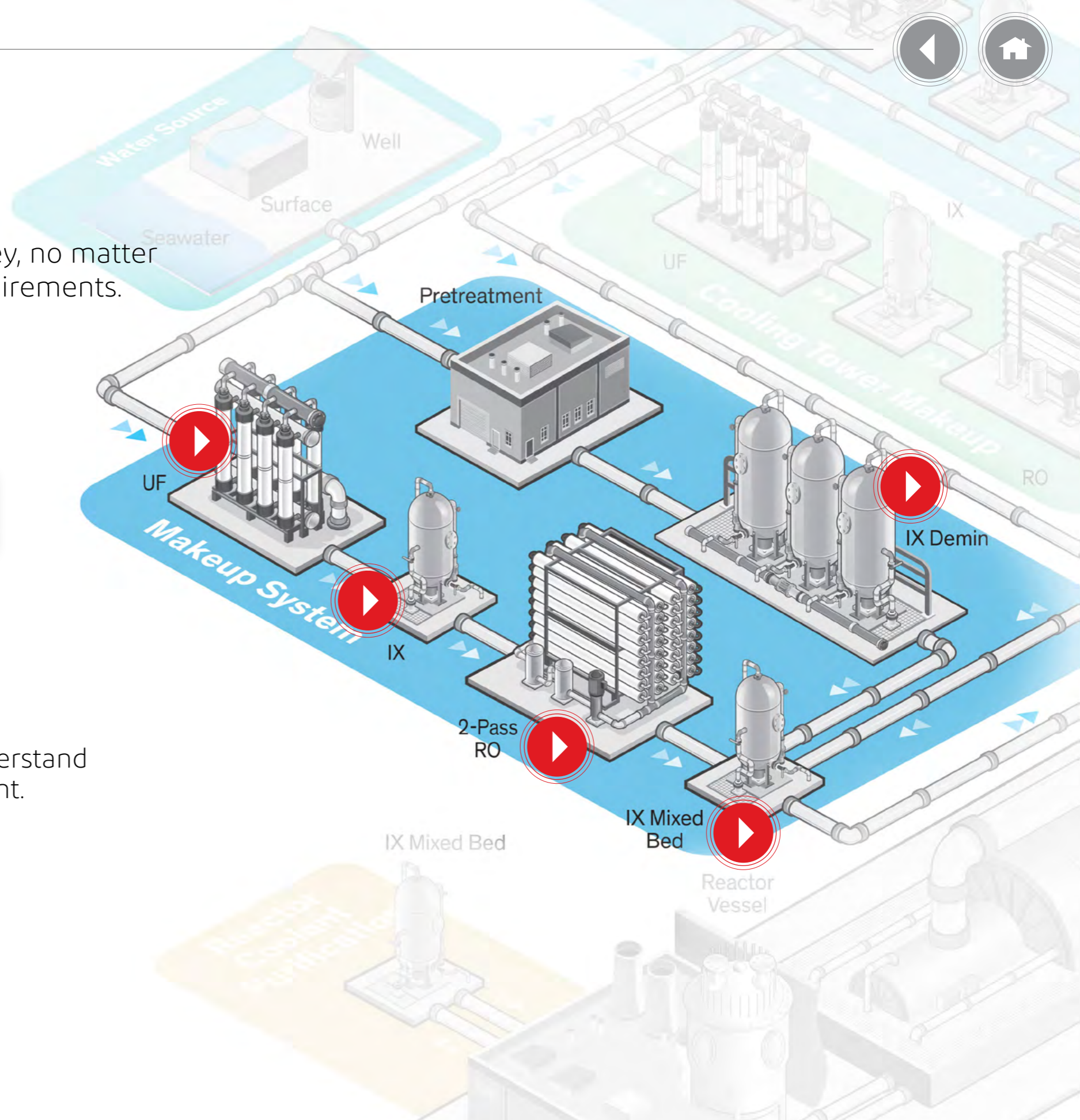



NUCLEAR POWER PLANT WATER TREATMENT • BOILER WATER MAKEUP

THE CHALLENGE



Fresh makeup water replaces losses from evaporation and blowdown in the steam/condensate loop. Varying feed conditions and boiler demands make operational efficiency difficult to maintain. To avoid scaling and corrosion, contaminants must be maintained at sub ppm levels. Over time, as power plant designs have been upgraded for higher efficiency, the metallurgies and processes used have placed progressively higher demands on makeup water purity.

THE SOLUTION



Treatment steps depend on the required water quality vs. the raw water quality. Regardless of which demineralization technology you prefer, DuPont has you covered. We offer comprehensive solutions for your makeup water challenges that can achieve desired quality levels, leading to optimized water use, reduced asset corrosion and boiler downtime, and ultimately trimmed operational costs.

BACK

Common Designs

Multiple process schemes exist utilizing a combination of ultrafiltration, reverse osmosis and ion exchange technologies, including packed bed resins.

Classical schemes using ion exchange minimize electrical energy and water consumption when TDS is typically less than 700 ppm.

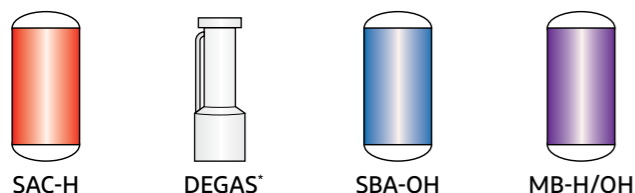

- Low TDS
- Low TOC
- Small flow rates

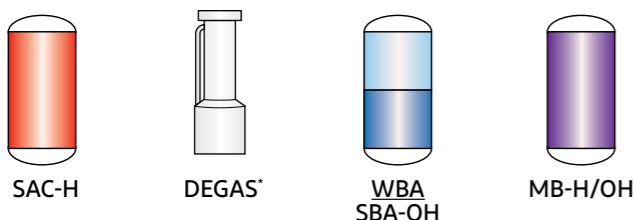

- Low-med TDS
- High TOC
- Insufficient TH/TAlk ratio

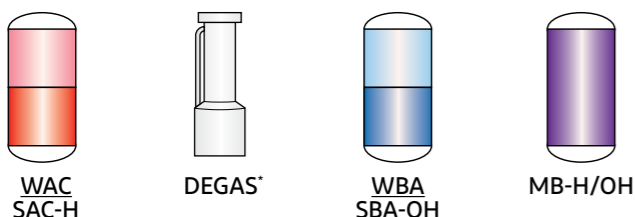

- Med - high TDS
- High TOC
- Sufficient TH/TAlk ratio

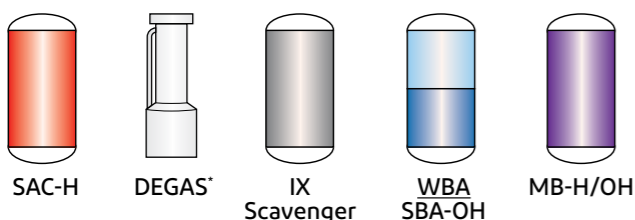

- Enhanced TOC removal

*In case of low alkalinity, degasifier tower may be optional

Becoming more widely adopted, schemes incorporating membranes reduce load on ion exchange resins, minimize chemical consumption and are more adept at handling challenging waters.

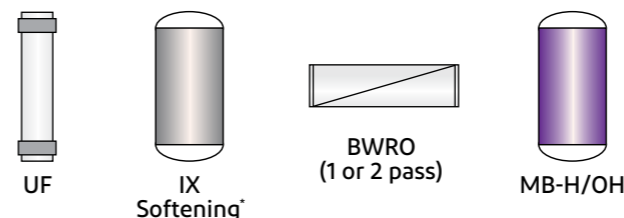

- Low TDS surface, ground or recycled wastewater (typically <1200 ppm as NaCl)

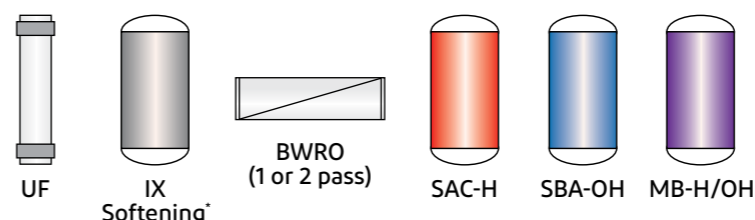

- Moderate TDS

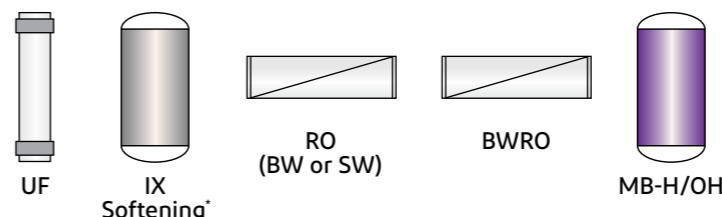

- High TDS brackish (typically <2000 ppm) or seawater (typically >30,000 ppm)

*Optional, dependency on inlet water quality

BACK

CONTACT AN EXPERT



Ion Exchange Demineralization (IX Demin)

Ion Exchange removes all cations, anions, and large organic contaminants. IX demineralization consists of at least two resin beds: a hydrogen form strong acid cation resin followed by a hydroxide form strong base anion resin. A degasifier may be used between them to remove alkalinity. Weak acid cation and/or weak base anion may also be incorporated, depending on levels of TDS, hardness, TOC and alkalinity.

DuPont Unique: The widest range of industry-leading, reliable ion exchange resins from world-class manufacturing facilities.

Benefits:

- Reduce key ionic contaminants down to the microgram per liter concentrations required for steam generation in nuclear power plants

The Numbers:

- Save up to 40% in OPEX and receive up to 10x better water quality by using reverse flow beds over conventional co-flow systems
- Further lower cost by 25% using AMBERPACK™ and UPCORE™ packed beds, which use less regenerant and service water

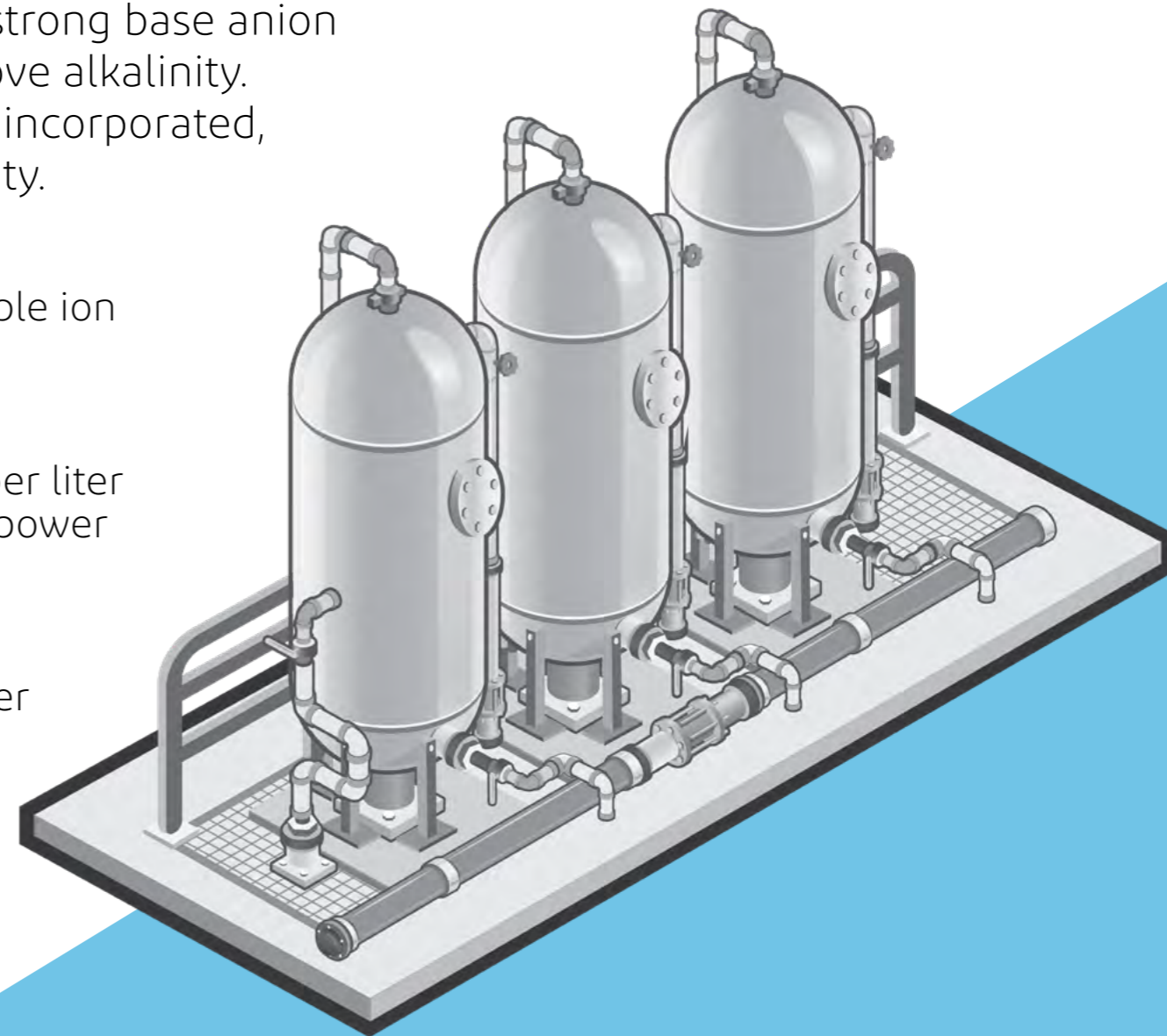
[BACK](#)[RECOMMENDED PRODUCTS](#)

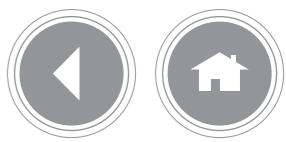

Ultrafiltration (UF)

Ultrafiltration technology removes colloids, particles and bacteria in a continuous system.

DuPont Unique: Provides the market's highest membrane active area, translating to smaller system footprint. All DuPont UF products are made with high chemical resistance PVDF that reduces fouling and improves cleaning performance; providing higher system reliability and lower maintenance.

Benefits:

- Prevent or reduce fouling on demineralization unit, ideally used as a pre-treatment for downstream units like RO
- Reduce the impact of poor or highly variable source water on your boiler feedwater management
- Modularized, with a high level of automation and significantly smaller footprint than conventional filtration systems
- High recovery at 90-95%

The Numbers:

- Reduce RO cleaning needs by as much as 50% by using ultrafiltration as a pretreatment

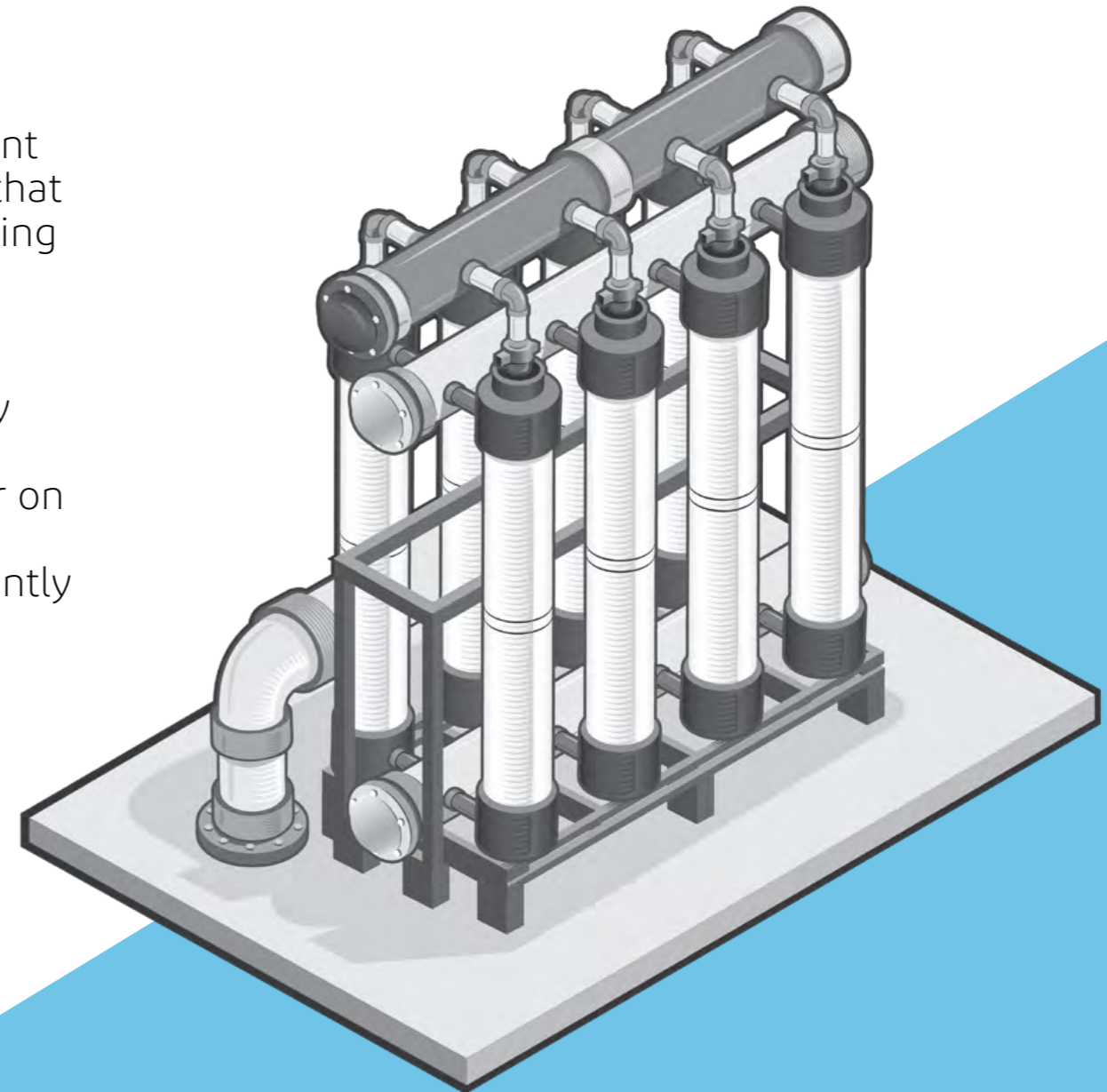
[BACK](#)[RECOMMENDED PRODUCTS](#)

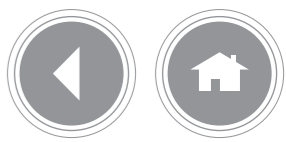

Ion Exchange (IX) Pretreatment

Purification technology that can work in high TDS/contaminant conditions to remove dissolved solids, total organic carbon, and other potential foulants.

DuPont Unique: Recognized world-leading ion exchange brands offer superior strength and quality. DuPont offers a comprehensive range of ion exchange resins to suit the most stringent water purity requirements and operating parameters.

Benefits:

- Prevent scaling in downstream RO and avoid the complication and expense of using antiscalants by incorporating softening resins to remove hardness from makeup water
- Protect RO and/or UF by using strong acid cation resins to help remove certain cationic polymers present from upstream coagulation systems
- Protect downstream demineralizers and RO units with tailored strong base anion scavenging resins that remove certain organic species

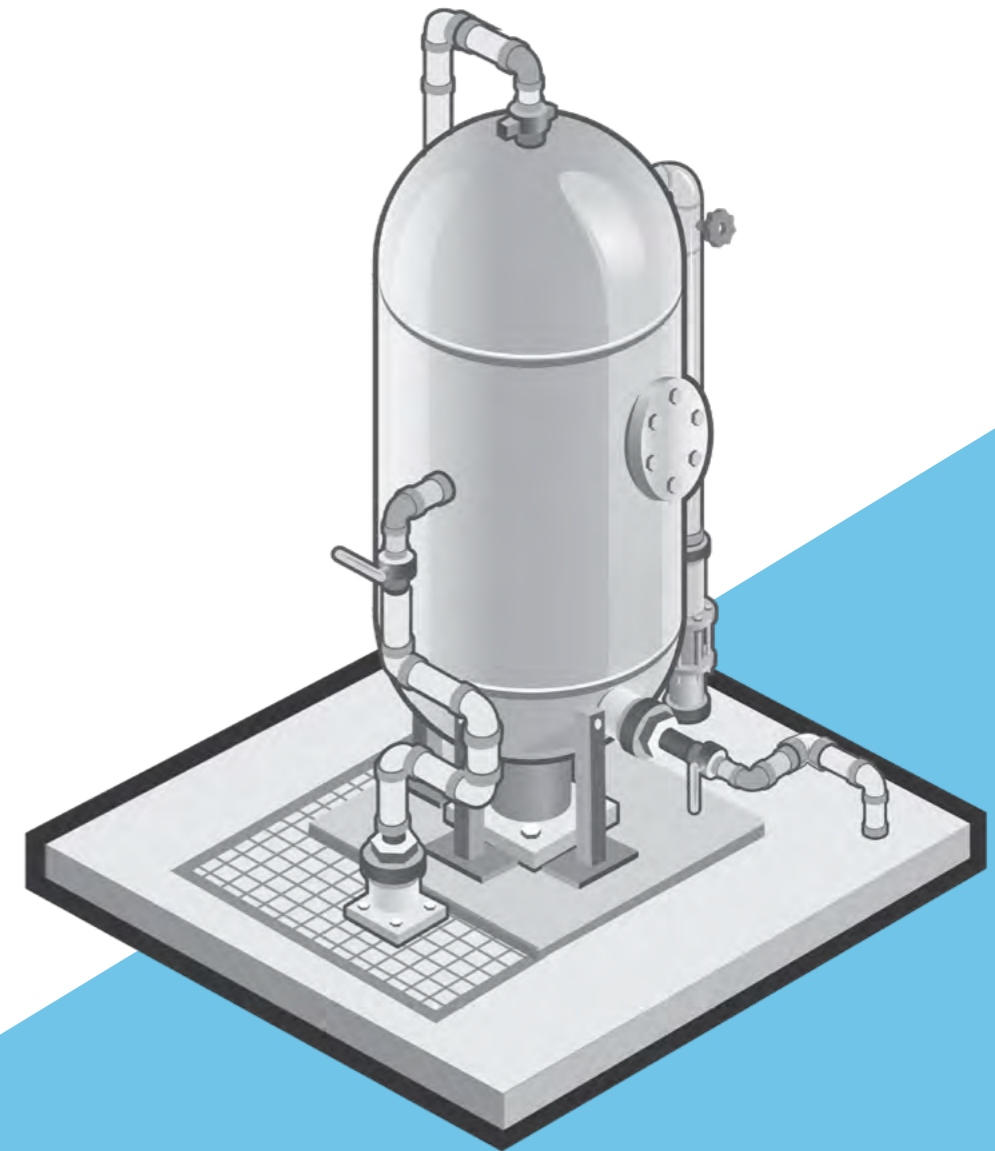
[BACK](#)[RECOMMENDED PRODUCTS](#)

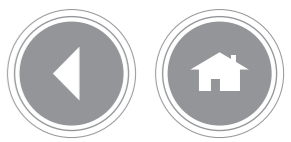

Reverse Osmosis/Nanofiltration (RO/NF)

Pressure driven filtration technology that removes molecules and ions from boiler water makeup water. Removes down to a specific ion level (Ca, Mg, Fe, Si, Al).

DuPont Unique: Recognized world leader in RO and NF technologies for demineralizing brackish water or desalinating seawater.

Benefits:

- Prevent or reduce scalants, foulants and ions from entering the steam cycle
- Lower the blowdown rate and reduce total water intake
- Enable use of alternative feedwater sources, such as wastewater, to reduce overall water footprint
- Reduce the impact of poor or highly variable source water on your boiler water management
- Remove silica to reduce regeneration frequency of downstream IX MB

The Numbers:

- Reduce energy costs by over 30% by using high rejection, low energy innovative RO membrane technologies while improving water quality up to 40% against standard RO offerings

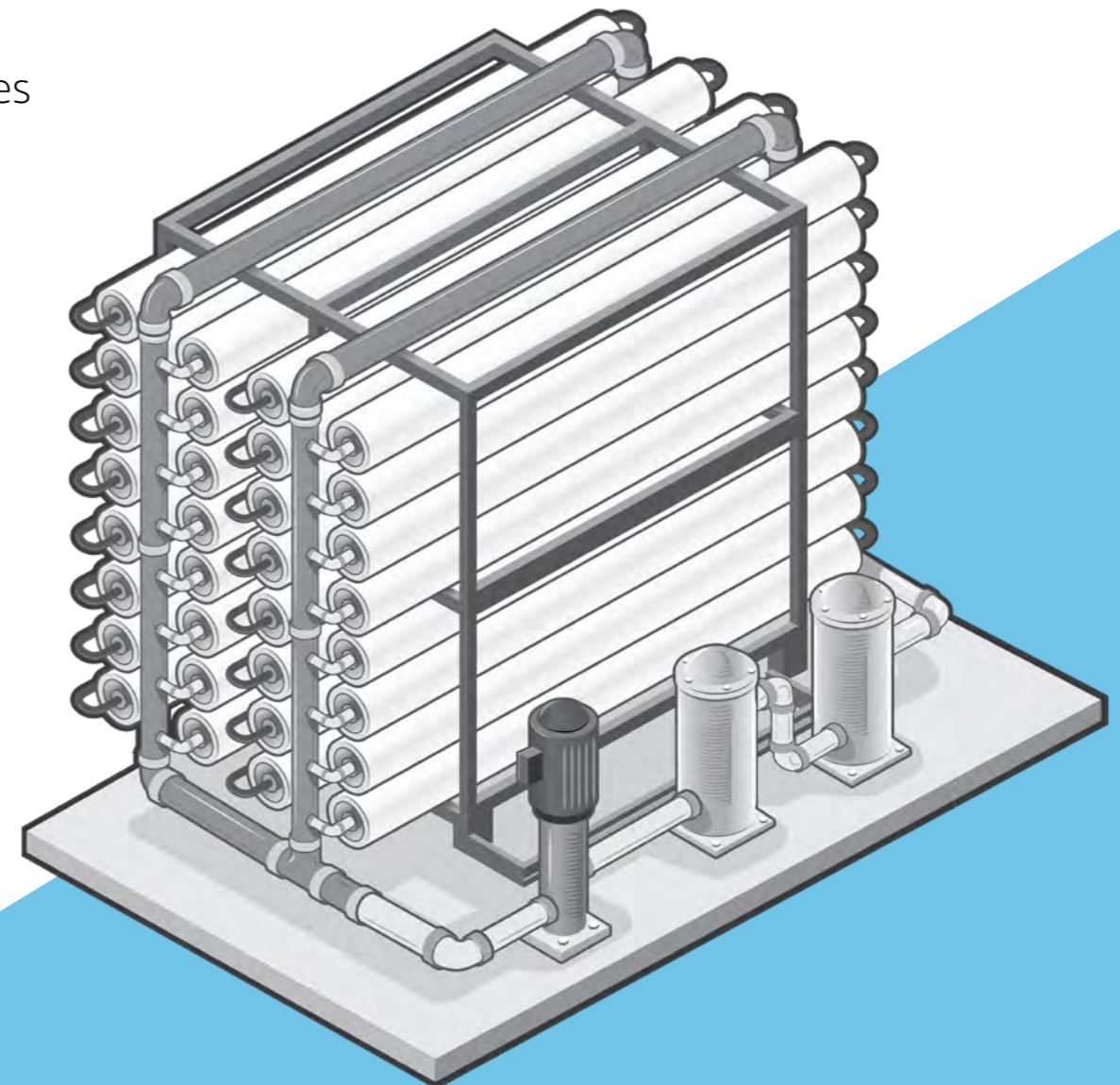
[BACK](#)[RECOMMENDED PRODUCTS](#)



Ion Exchange Mixed Bed (IX MB)

Purification technology ideal to remove residual contaminants typically present in the low ppm to ppb range. IX MB is the standard final polishing step for boiler makeup.

DuPont Unique: A comprehensive range of uniform particle size (UPS) ion exchange resins, recognized for superior strength and quality, to suit the most stringent water purity and operating parameters for working and polishing mixed beds.

Benefits:

- Great combination of trace contaminant removal, reliability, and cost effectiveness
- Optimize water quality with efficient regeneration and long life when using UPS MB resins with high kinetics and comparatively low pressure drop

The Numbers:

- Lower ionic leakage by 10-50% using UPS MB resins, resulting in longer run lengths (typically 10-30%) and higher water purity than most conventional MB resins

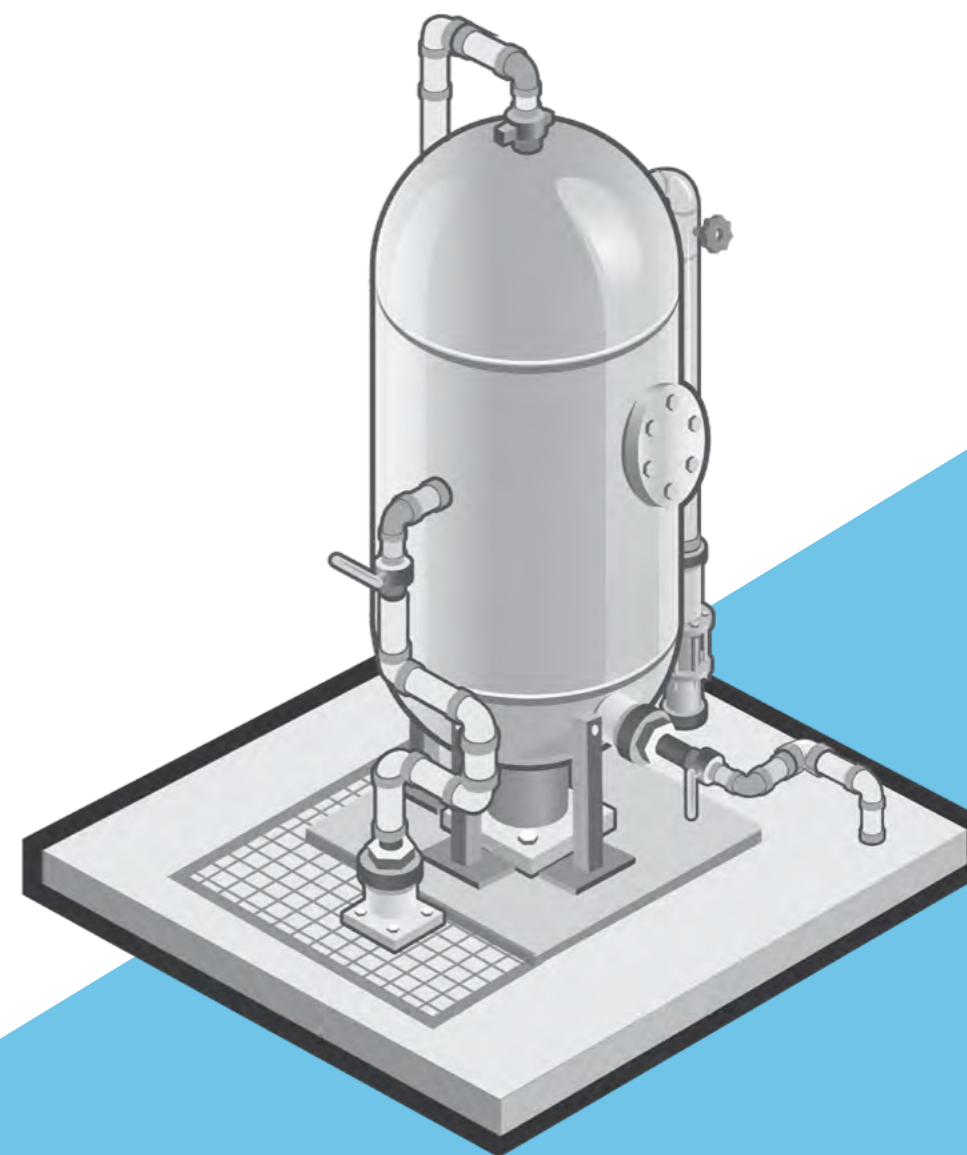
[BACK](#)[RECOMMENDED PRODUCTS](#)

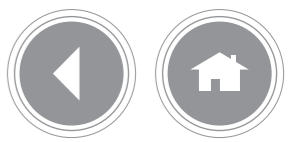

The right makeup for any water.

Don't let cooling water limit production. Meet any makeup water challenge with novel and advanced technologies.

SEE HOW

COMMON DESIGNS

RECOMMENDED PRODUCTS

Click on technologies to better understand their role in makeup water treatment.

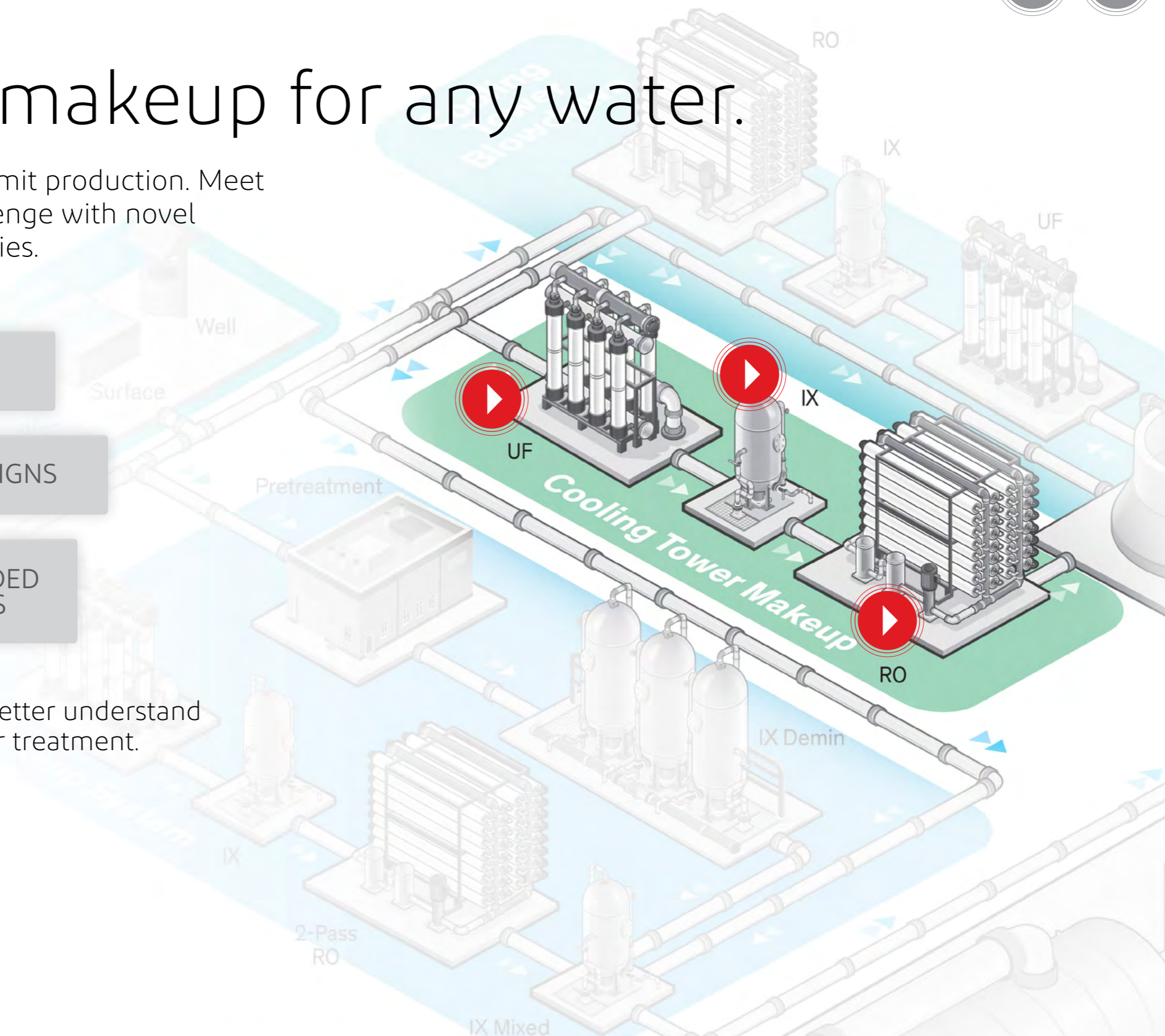



NUCLEAR POWER PLANT WATER TREATMENT • COOLING WATER MAKEUP

THE CHALLENGE



Cooling tower systems require a constant source of water due to losses from drift, evaporation, and blowdown. Depending on water source, region, and cooling tower type, several advanced filtration technologies and chemistries may be necessary to properly ready the makeup water before entering the cooling tower system.

THE SOLUTION



DuPont can help you reduce corrosion, scale, biofouling, and other asset-limiting concerns no matter the fresh water source, abundance of water, or condition. We will work with you to determine an appropriate mix of technologies, including ultrafiltration (UF), reverse osmosis (RO), and nanofiltration (NF).

BACK

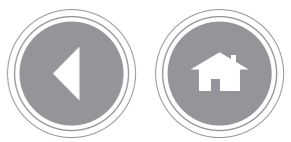

Common Designs

Cooling water makeup treatment is often combined with portions of a boiler makeup system.

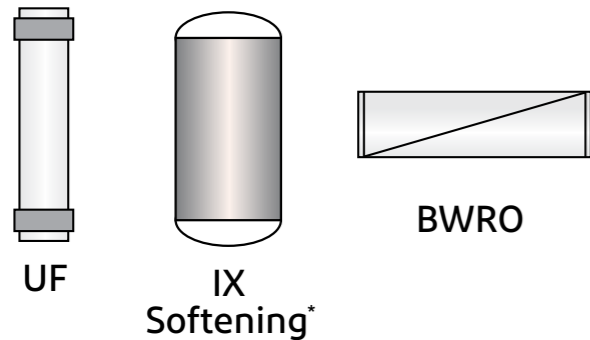

- Reduce cooling tower scale and corrosion
- Reuse of BWRO reject
- Higher RO recovery



- Colloidal and particulate removal

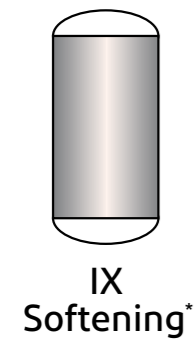

- Reduce cooling tower scale and corrosion

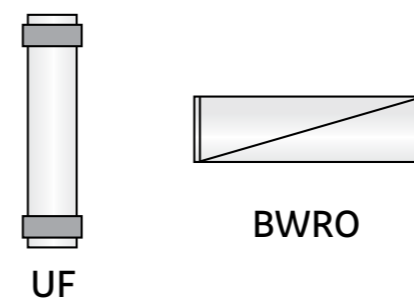

- Reduce cooling tower scale and corrosion

**optional, dependency on inlet water quality*

BACK

CONTACT AN EXPERT

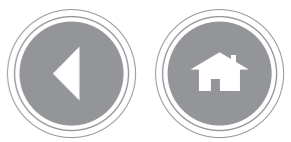

Ultrafiltration (UF)

Ultrafiltration technology removes colloids, particles and bacteria in a continuous system.

DuPont Unique: Provides the market's highest membrane active area, translating to smaller system footprint. All DuPont UF products are made with high chemical resistance PVDF that reduces fouling and improves cleaning performance; providing higher system reliability and lower maintenance.

Benefits:

- Reduce the impact of poor or highly variable source water on your cooling tower management
- Prevent or reduce fouling on demineralization unit, ideal to be used as a pre-treatment for downstream units like RO
- Modularized, with a high level of automation and significantly smaller footprint than conventional filtration systems
- High recovery at 90-95%

The Numbers:

- Reduce RO cleaning needs by as much as 50% when using ultrafiltration as a pretreatment

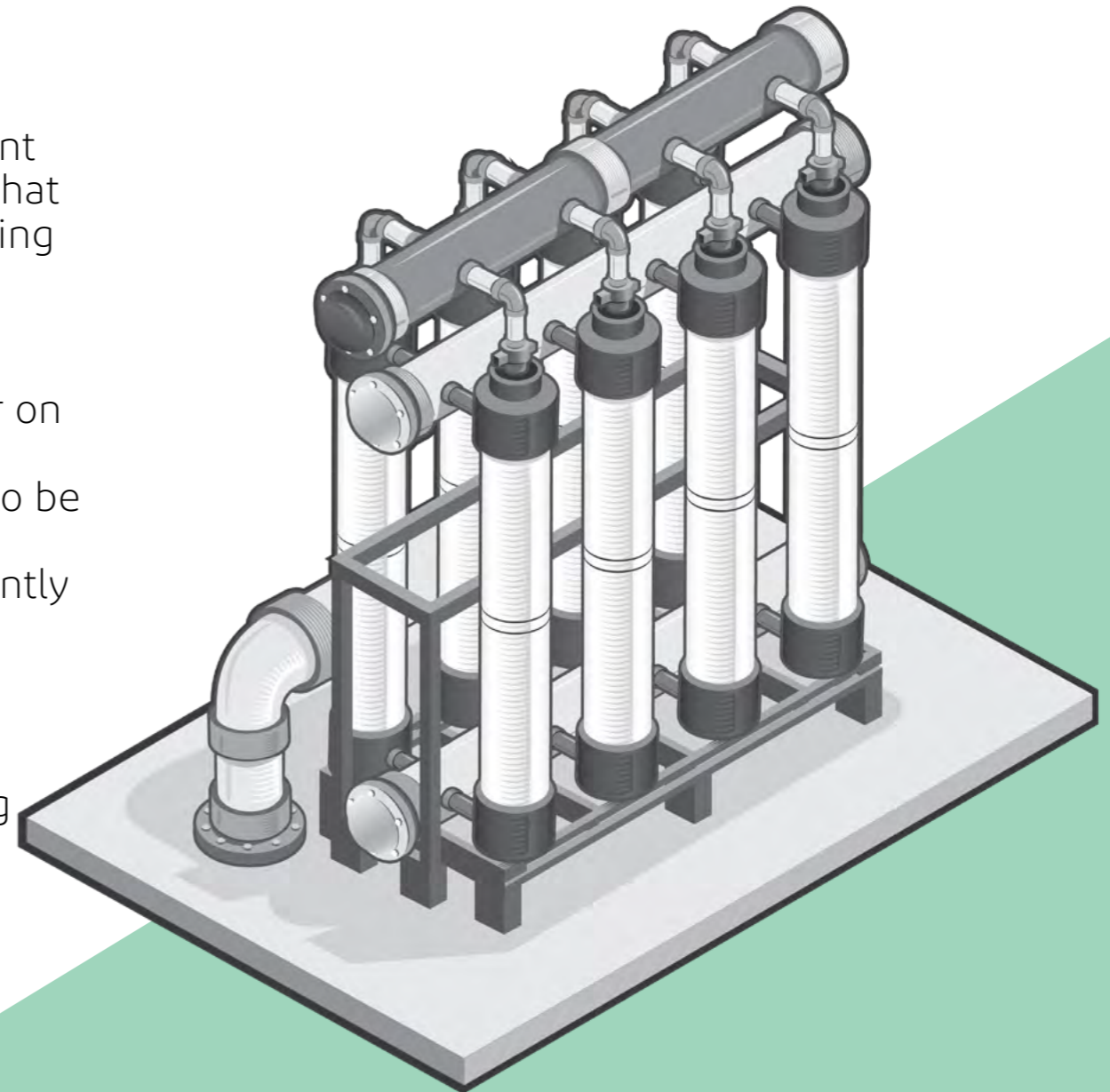
[BACK](#)[RECOMMENDED PRODUCTS](#)

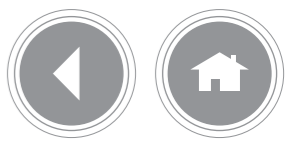

Ion Exchange (IX) Pretreatment

Purification technology that can work in high TDS/contaminant conditions to remove dissolved solids and total organic carbon.

DuPont Unique: Recognized world-leading ion exchange brands offer superior strength and quality. DuPont offers a comprehensive range of ion exchange resins to suit the most stringent water purity requirements and operating parameters.

Benefits:

- Prevent scaling in the cooling tower or downstream RO treatment and avoid the complication and expense of using antiscalants by incorporating softening resins to remove hardness from makeup water
- Strong and weak acid cation industrial softening resins can be tailored to fit your specific needs

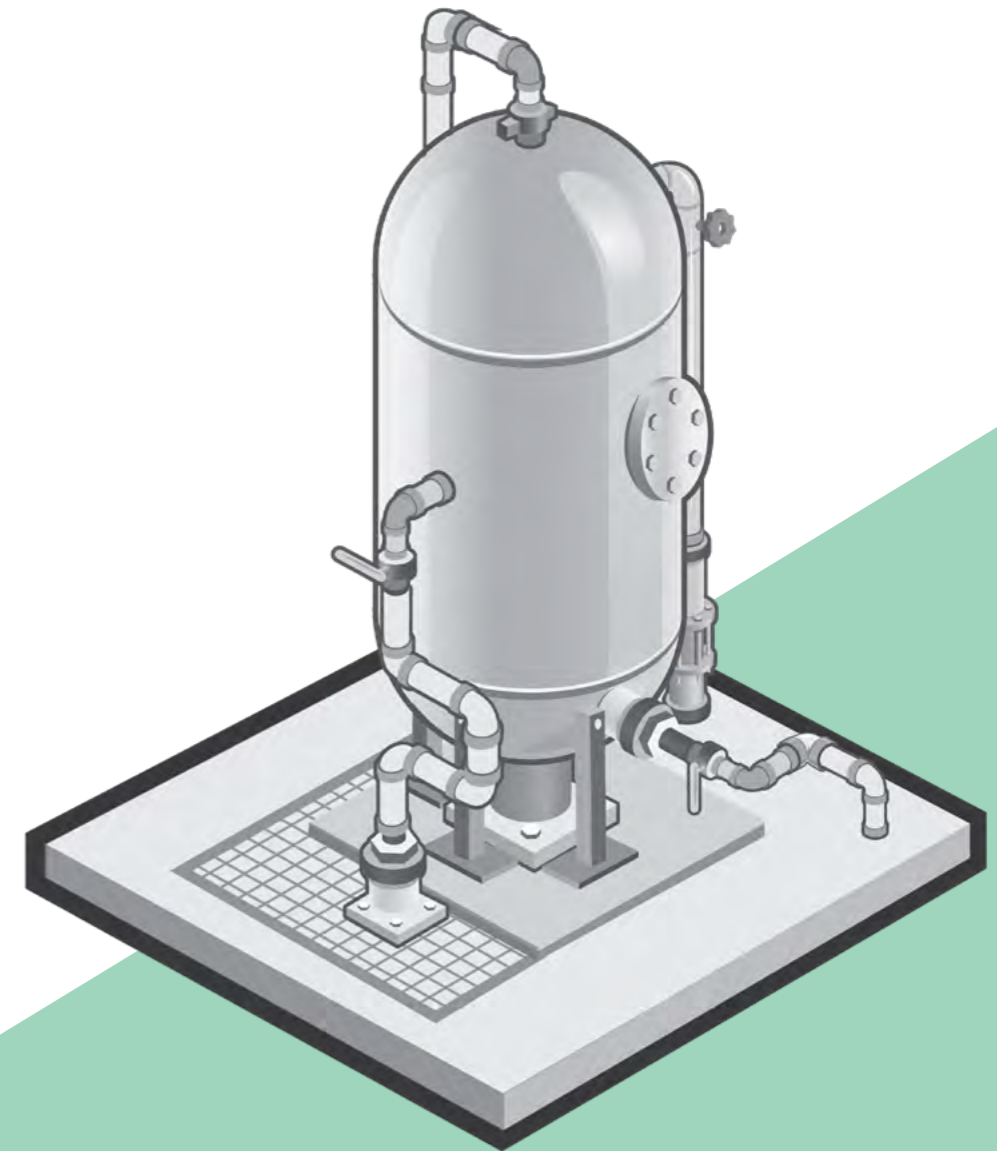
[BACK](#)[RECOMMENDED PRODUCTS](#)

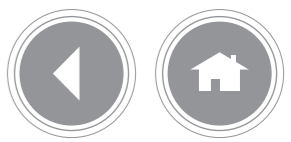

Reverse Osmosis (RO)/Nanofiltration (NF)

Filtration technology that can remove many types of molecules and ions, down to a specific ion level (Ca, Mg, Fe, Si, Al).

DuPont Unique: Recognized world leader in RO and NF technologies for demineralizing brackish water or desalinating seawater.

Benefits:

- Prevent or reduce scalants, foulants and ions from entering cooling towers
- Increase number of cycles in cooling tower and reduce water intake
- Enable use of alternative feedwater sources, such as wastewater, to reduce overall water footprint
- Reduce amount of chemicals needed for cooling water control
- Reduce the impact of poor or highly variable source water on your cooling water management

The Numbers:

- Save 20-60% in water intake by recirculating your cooling tower twice as often

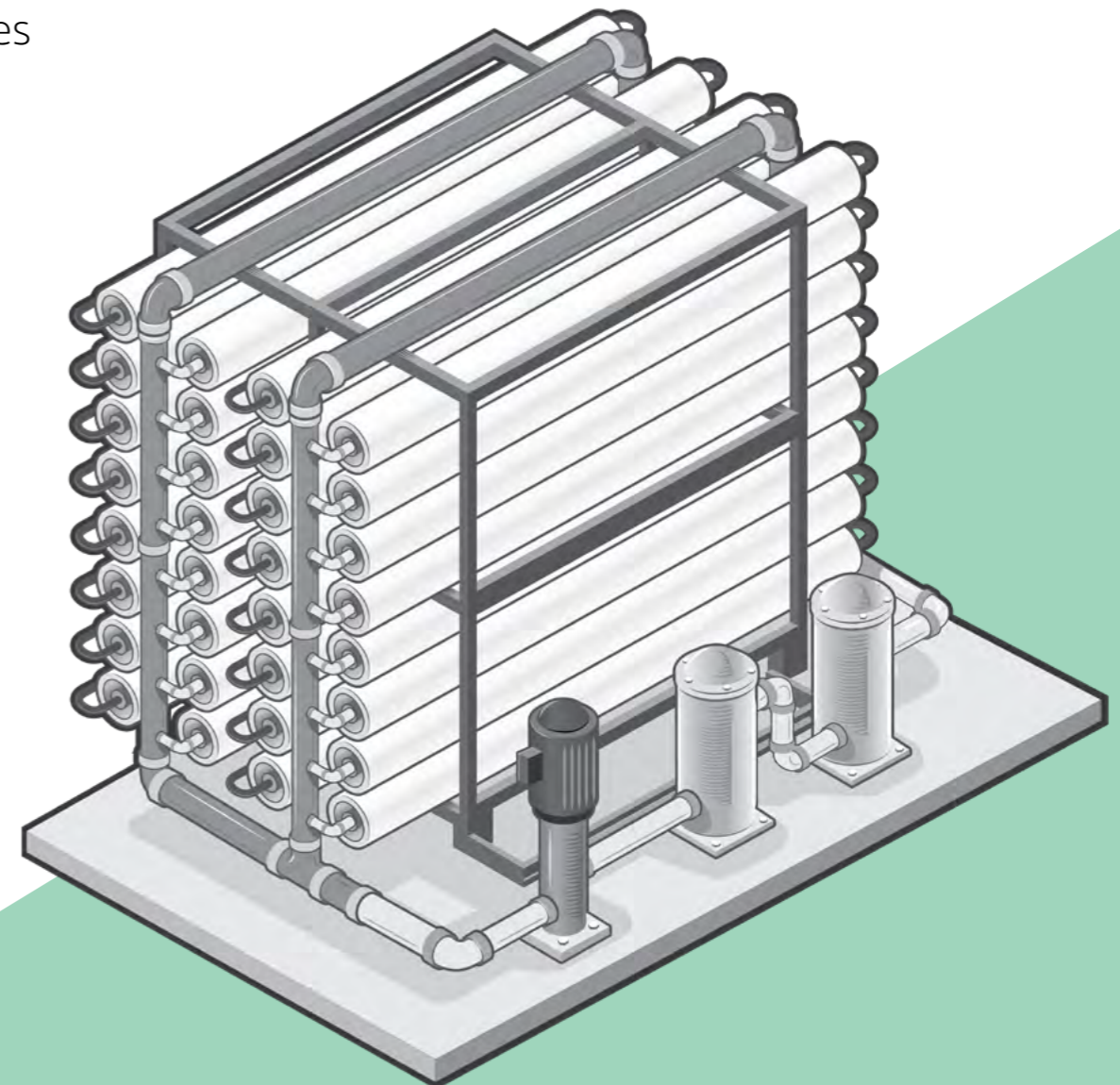

BACK

RECOMMENDED
PRODUCTS

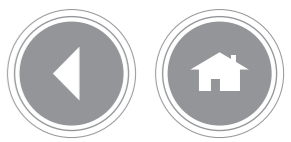

A cooling touch.

Recover and reuse blowdown to meet compliance and minimize use of makeup water.

SEE HOW

COMMON DESIGNS

RECOMMENDED PRODUCTS

Click on technologies to better understand their role in blowdown treatment.

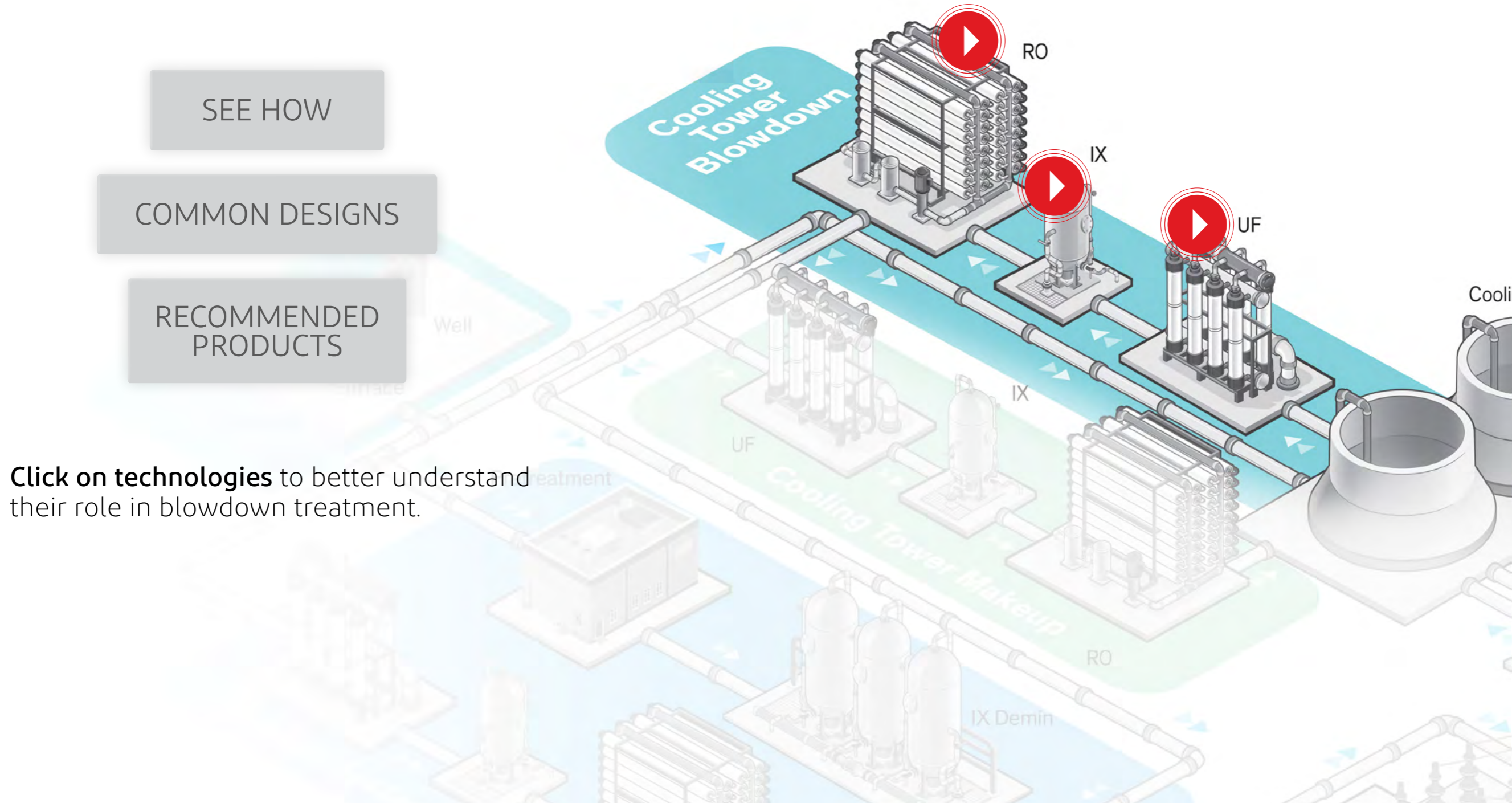



NUCLEAR POWER PLANT WATER TREATMENT • COOLING TOWER BLOWDOWN REUSE

THE CHALLENGE



Recirculating cooling water lowers a power plant's withdrawal requirement, but the circuit must be blown down periodically to prevent salt buildup as water evaporates in the towers. Because the blowdown is too dirty to be reused without treatment, it is typically sent directly to the wastewater treatment plant. This imposes a hydraulic load on the wastewater treatment system. More importantly, a tremendous amount of relatively clean water is wasted, adding significant cost and compliance complexity.

THE SOLUTION



Treatment and reuse of blowdown is becoming more common throughout the world as water scarcity drives policy decisions. DuPont experts work with you to deliver the optimal solution for your needs, using robust, reliable, fouling-resistant, filtration and purification technologies to recover and return up to 90% of blowdown water for makeup.

BACK

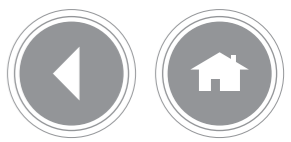

Common Designs

Cooling tower blowdown can vary by makeup source and pretreatment but is typically high in scaling and fouling potential.

Schemes incorporating only membranes can be used when the inlet hardness and/or the desired recovery are low.

Softening pre-treatment, via precipitation, ion exchange, or even both, may be required in more challenging waters with high hardness.

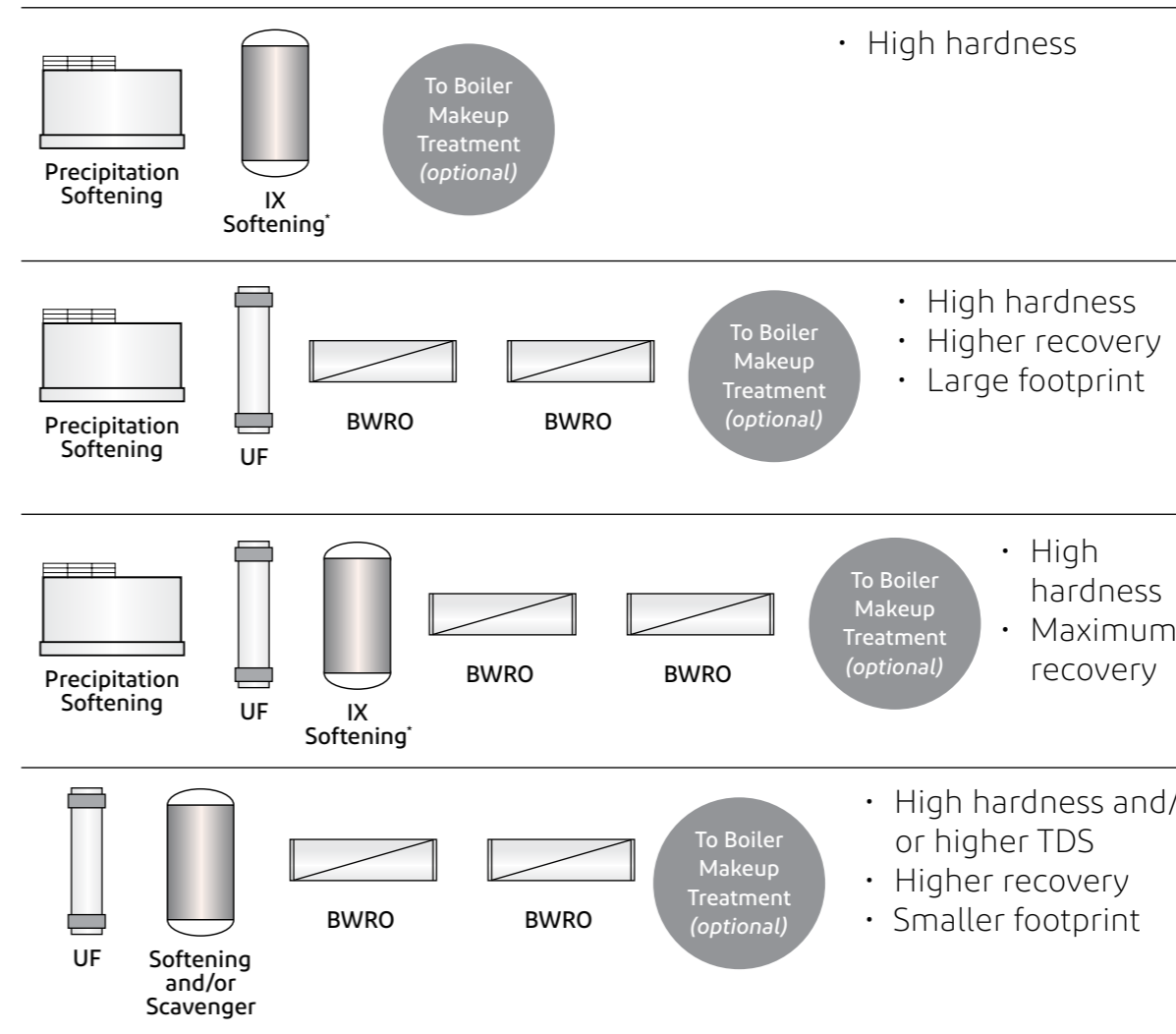
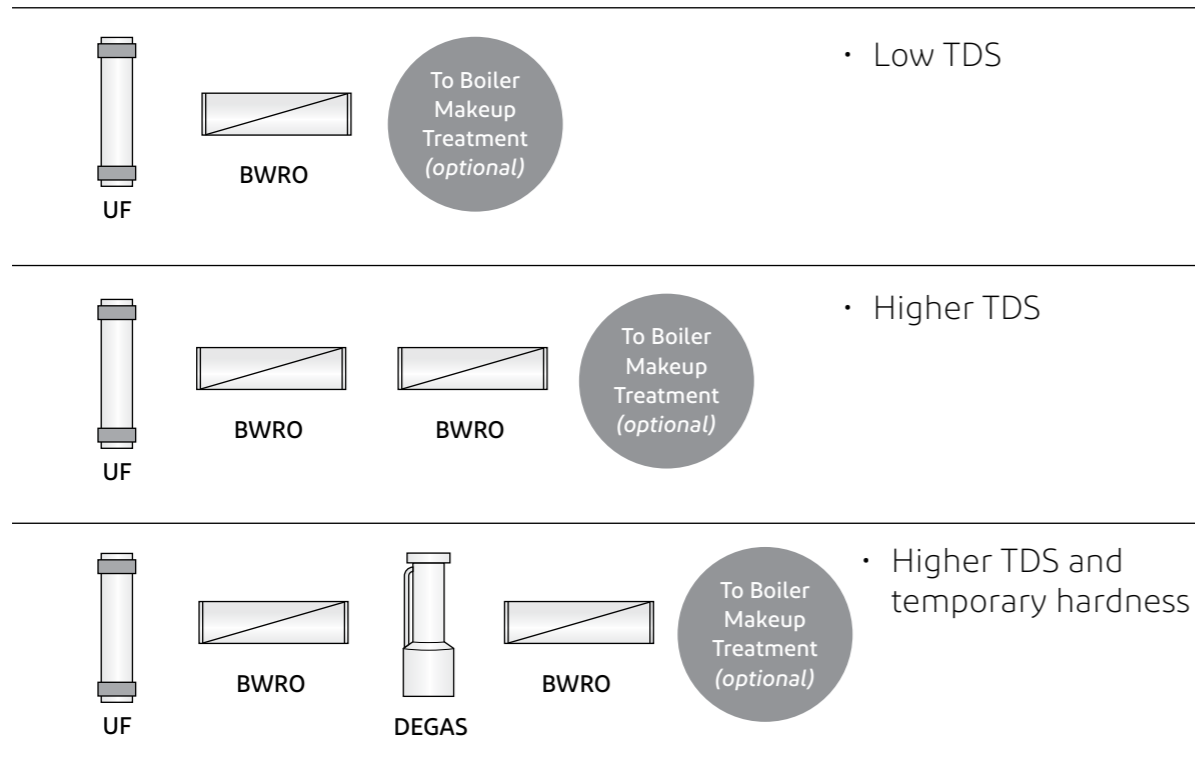

BACK

CONTACT AN EXPERT

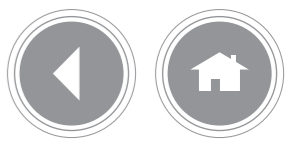

Ultrafiltration (UF)

Ultrafiltration technology removes colloids, particles and bacteria in a continuous system. It is optimally used in recycled water streams.

DuPont Unique: Provides the market's highest membrane active area, translating to smaller system footprint. All DuPont UF products are made with high chemical resistance PVDF that reduces fouling and improves cleaning performance; contributing to higher system reliability and lower maintenance. Durable to withstand rigors of treating tough-to-clean CTBD wastewater.

Benefits:

- Prevent or reduce fouling on CTBD treatment unit, ideally used as pre-treatment for operations like RO
- Reduce the impact of poor water quality on ability to recover and reuse CTBD
- Modularized, with a high level of automation and significantly smaller footprint than conventional filtration systems
- High recovery at 90-95%

The Numbers:

- Reduce RO cleaning needs by as much as 50% by using ultrafiltration as a pretreatment

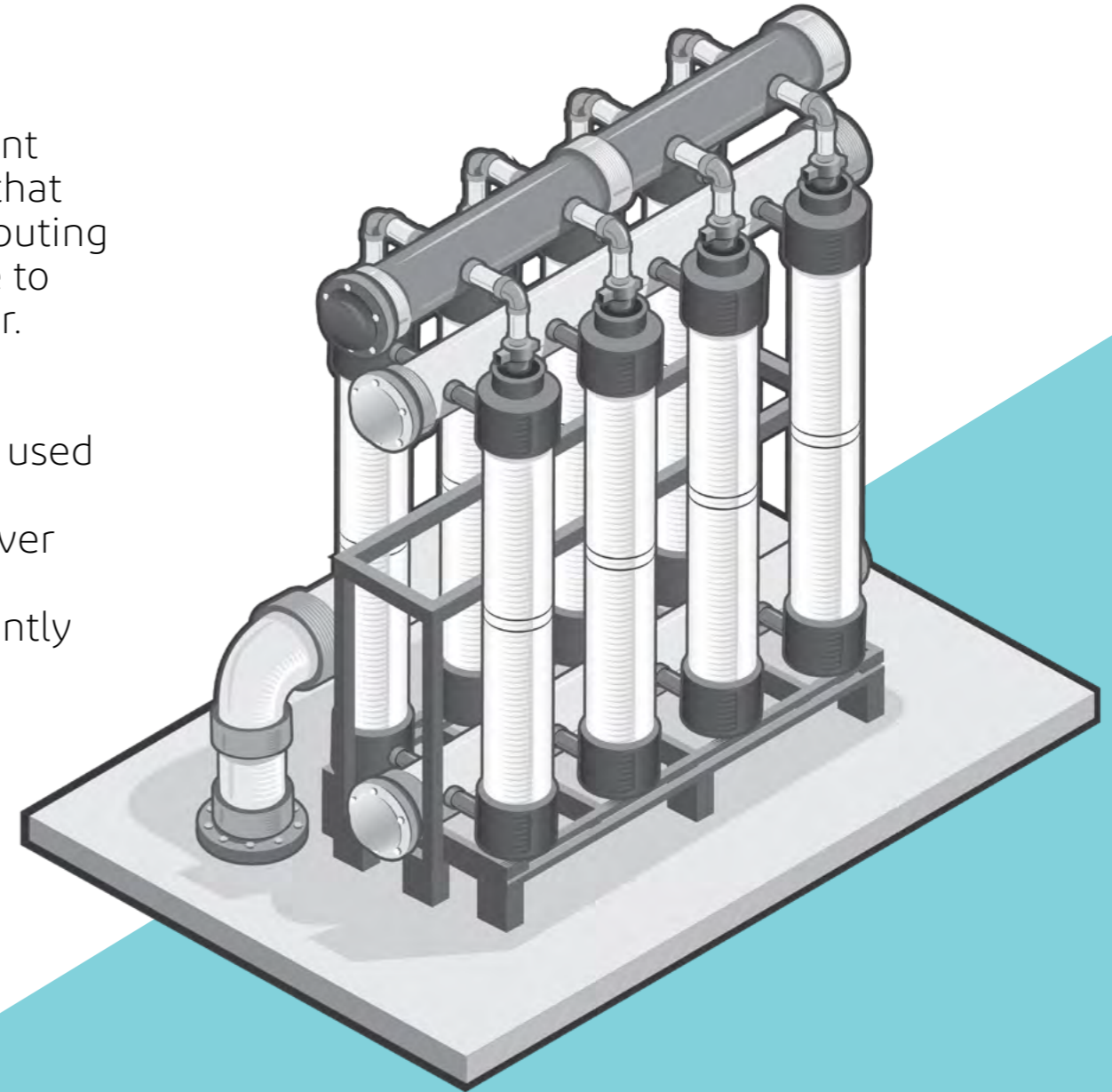
[BACK](#)[RECOMMENDED PRODUCTS](#)



Ion Exchange (IX) Pretreatment

Purification technology that can work in high TDS/contaminant conditions to remove dissolved solids, total organic carbon, and other potential foulants.

DuPont Unique: Offers a comprehensive range of ion exchange resins, recognized for superior strength and quality, to suit your operational needs.

Benefits:

- Prevent scaling in the cooling tower circuit or downstream RO and avoid the complication and expense of using antiscalants by incorporating softening resins to remove hardness from blowdown
- Protect RO and/or UF by using strong acid cation resins to remove certain cationic polymers present from upstream coagulation systems
- Protect downstream demineralizers and RO units with tailored strong base anion scavenging resins that remove certain organic species commonly found in CTBD wastewater

The Numbers:

- Realize up to 90% reuse of the cooling tower blowdown by adding industrial softening in front of dual membrane technology (UF + RO)

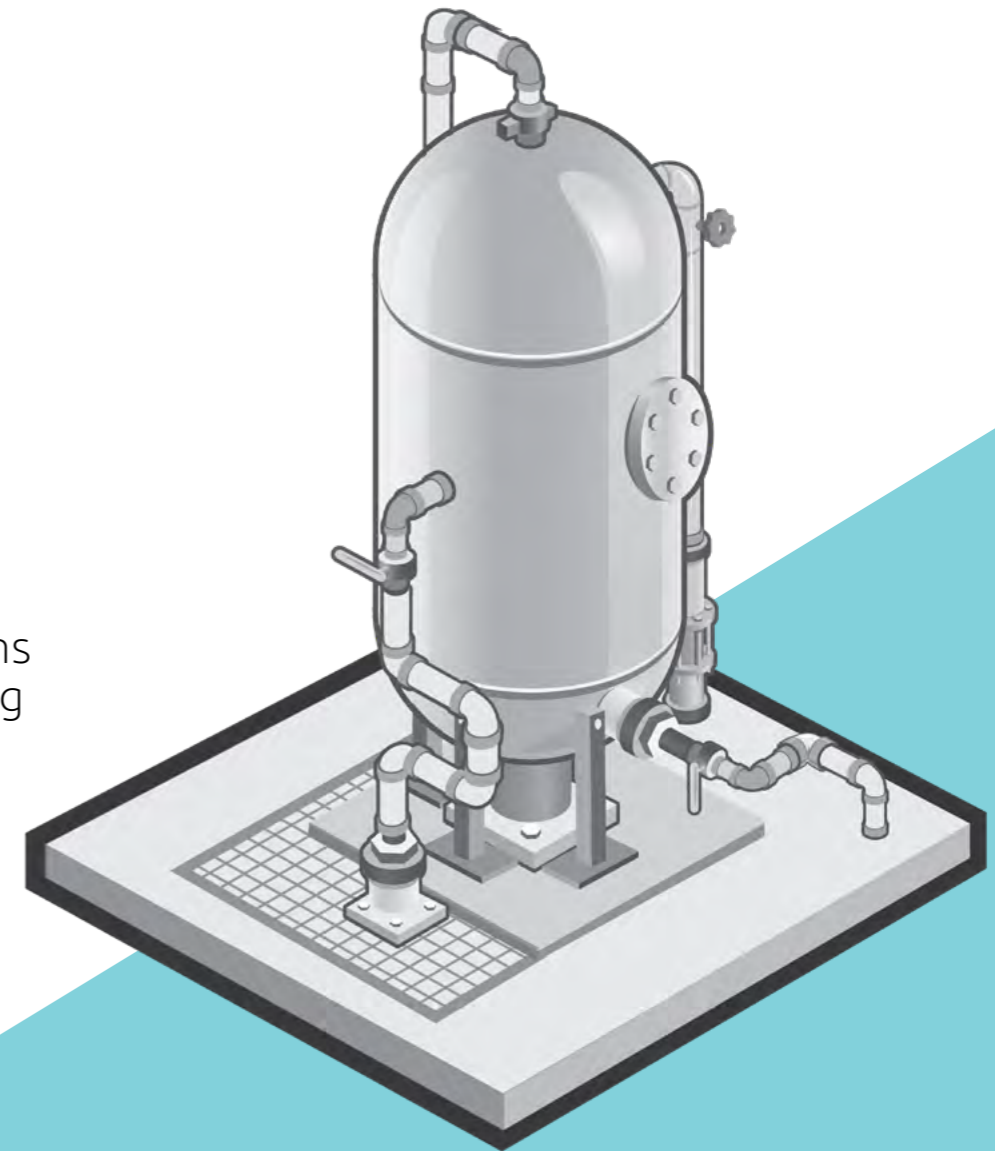
[BACK](#)[RECOMMENDED PRODUCTS](#)

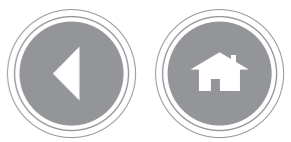

Reverse Osmosis/Nanofiltration (RO/NF)

Purification technology that can work in high TDS/contaminant conditions to remove dissolved solids, total organic carbon, and silica.

DuPont Unique: Recognized world leader in RO and NF technologies for demineralizing difficult-to-treat streams. Unique design and automated manufacturing makes them the market's most durable, fouling resistant, cleanable and reliable.

Benefits:

- Offers an ideal balance between efficient contaminant removal, demineralization, reliability and cost effectiveness
- Removes dissolved solids, silica, and total organic carbon prior to introducing water back into the cooling tower or boiler makeup system
- Tailored fouling resistant membranes handle high foulant loads from CTBD wastewater

The Numbers:

- Realize more than 70% reuse of the cooling tower blowdown when using dual membrane technology (UF + RO) together with proper pretreatment and chemical dosing

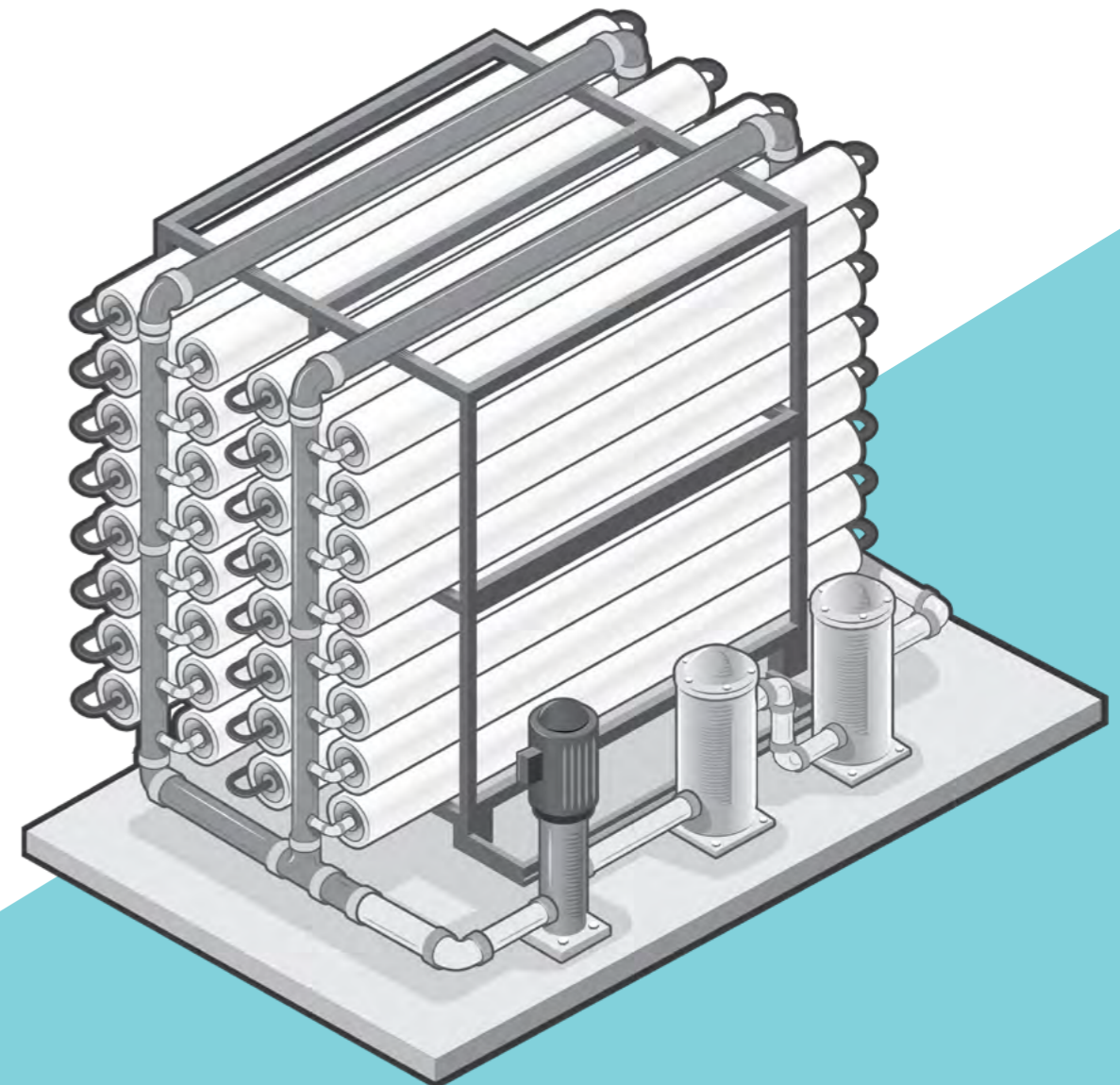
[BACK](#)[RECOMMENDED PRODUCTS](#)



Keep your circuit clean and protected.

Remove trace contaminants and protect against condenser leaks.

SEE HOW

COMMON DESIGNS

RECOMMENDED PRODUCTS

Click on **technologies** to better understand their role in condensate polishing treatment.

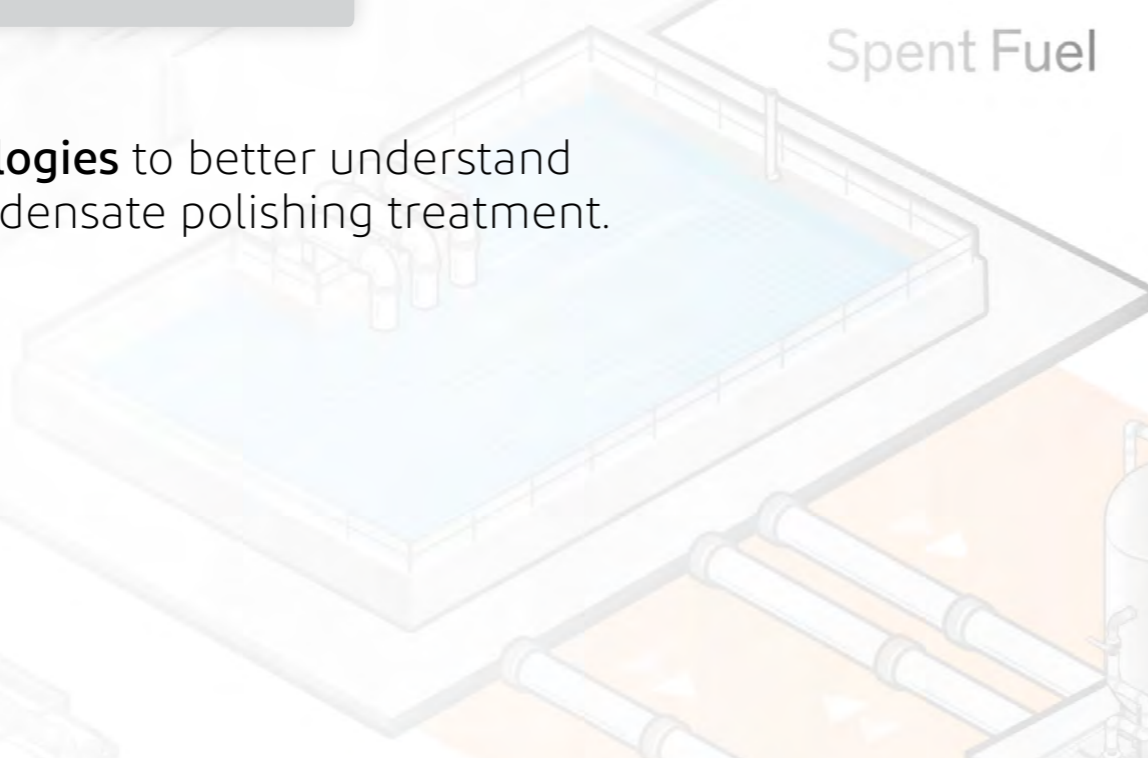

Turbine

IX Mixed Bed

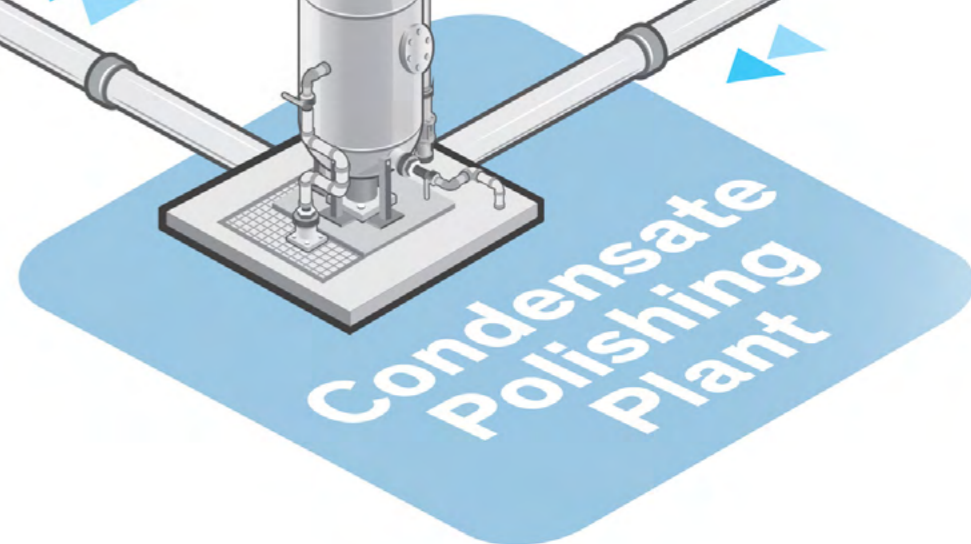

IX

IX Mixed Bed



Keep your circuit clean and protecto



NUCLEAR POWER PLANT WATER TREATMENT • CONDENSATE POLISHING

THE CHALLENGE



The primary circuit in BWR designs must be of the highest purity to minimize corrosion to critical components, as this loop uses pure water chemistry, with no pH control chemicals or moderators. The condensate polishing system must remove trace radioactive isotopes and corrosion products as well as protect against condenser leaks and makeup water upsets. Ion exchange resins used in BWR condensate polishing are non-regenerable and must have high purity, stability and capacity.

THE SOLUTION



DuPont's portfolio of nuclear grade resins has several offerings specifically tailored to meet the challenging demands of BWR condensate polishing. DuPont's manufacturing and low chloride regeneration processes result in the lowest chloride content and highest purity resins in the nuclear power industry. Our nuclear grade resins also offer the highest oxidative stability available. To provide longest lifetime, we also offer the highest loading capacity of any nuclear grade ion exchange resin available.

Click o
their r

BACK

Common Designs

A mixed bed ion exchange resin in the H/OH form is the standard for BWR condensate polishing.

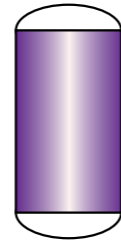

MB-H/OH

- Most common, highest ion exchange capacity

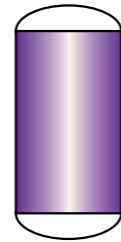

Powder
MB-H/OH

- Alternative with improved filtration

BACK



CONTACT
AN EXPERT

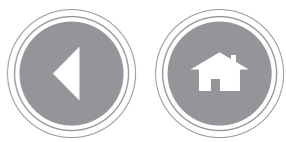

Ion Exchange Mixed Bed (IX MB)

Purification technology ideal to remove residual contaminants typically present in the low ppm to ppb range. IX MB is the standard for steam condensate treatment.

DuPont Unique: Recognized world-leading IX brands offer superior strength and quality for high performance in working and polishing MB applications.

Benefits:

- Great combination of trace contaminant removal, oxidative stability, capacity and operational life
- Ensure a more homogeneous mix at the bottom of service vessels when using nuclear grade MB polishing resins
- Help prevent transient chloride levels when new resin is placed into service by using nuclear grade anion resins

The Numbers:

- Avoid losses that could easily escalate to a million dollars a day by using resins with the strength and capacity to prevent reactor shutdowns during condenser leaks
- Reduce reactor sulfate levels by several fold for MBs containing DuPont's exceptionally high DVB crosslinker cation resin

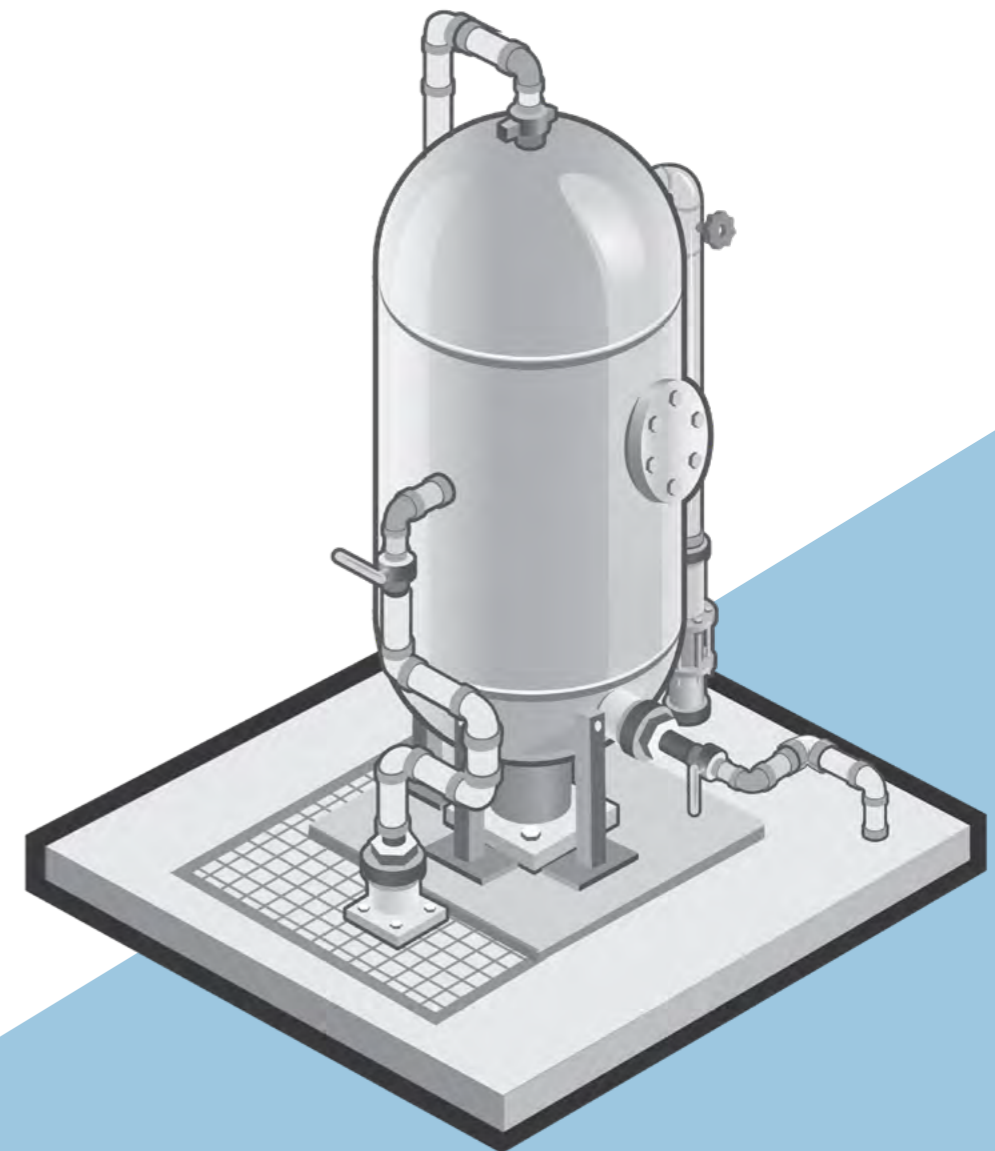
[BACK](#)[RECOMMENDED PRODUCTS](#)

Hot cleanup.

Cleanup all radioactive wastewater streams for safe and efficient disposal.

SEE HOW

COMMON DESIGNS

RECOMMENDED PRODUCTS

Click on technologies to better understand their role in rad waste treatment.

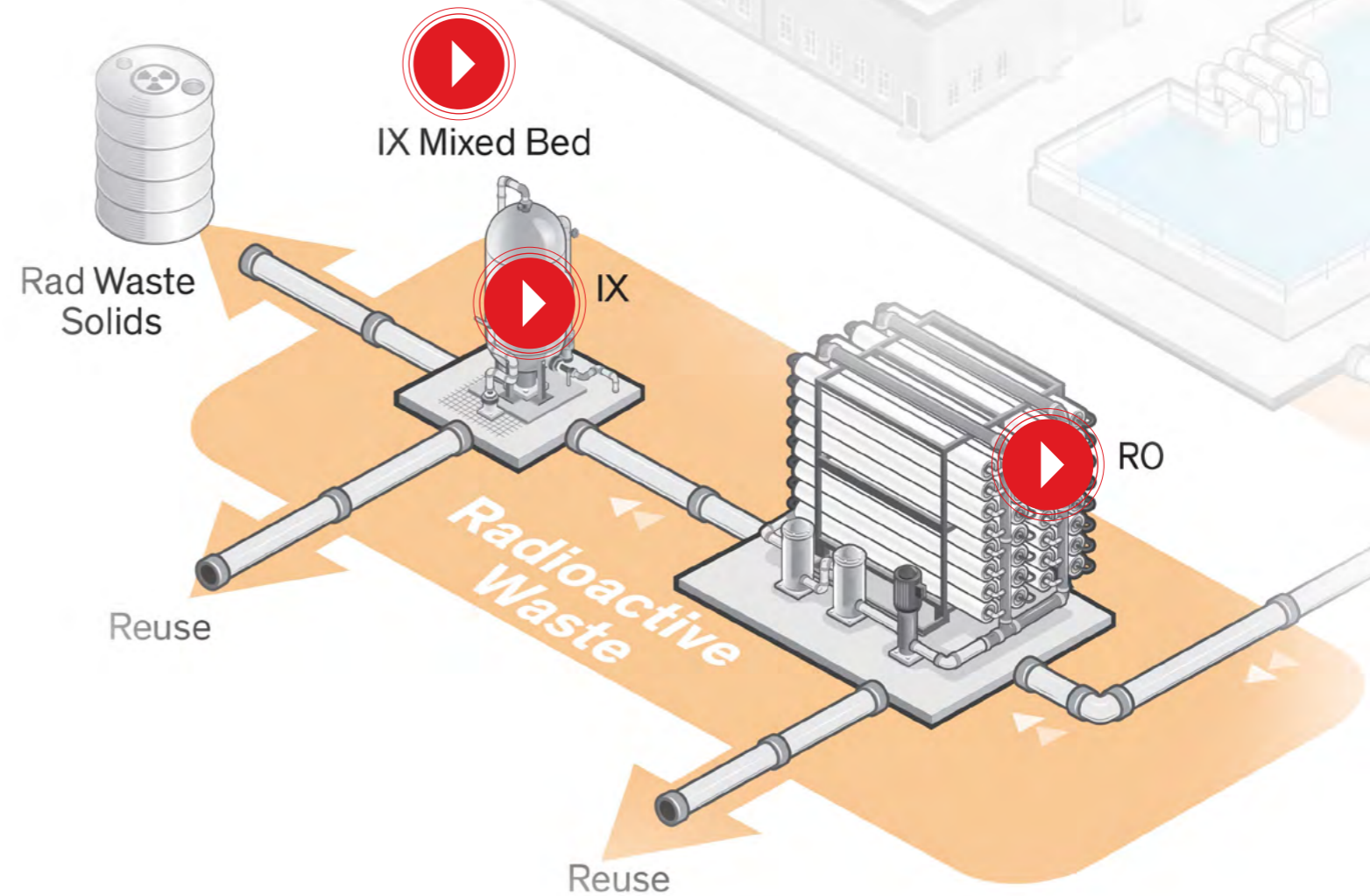



NUCLEAR POWER PLANT WATER TREATMENT • RADIOACTIVE WASTE

THE CHALLENGE



Regenerant and rinse effluents from the condensate polishing resins, water used for resin transfer from non-regenerable decontamination units, and other non-reusable effluents all contain radioactive species and must be decontaminated prior to disposal.

THE SOLUTION



Depending on the nature and amount of the contaminants, these wastes are generally either concentrated by evaporation, perhaps with reverse osmosis pre-concentration, or processed by ion exchange mixed bed. A proper configuration is critical in this application to realize long lifetime and minimize overall rad waste treatment costs.

BACK

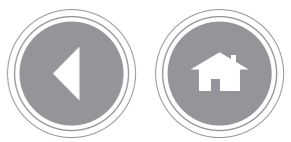

Common Designs

Ion exchange resins and membranes can be used to supplement or replace evaporative concentration methods for radioactive waste.

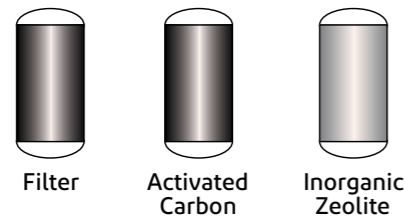

- Optional pre-treatment depending on site and needs

BACK

CONTACT AN EXPERT

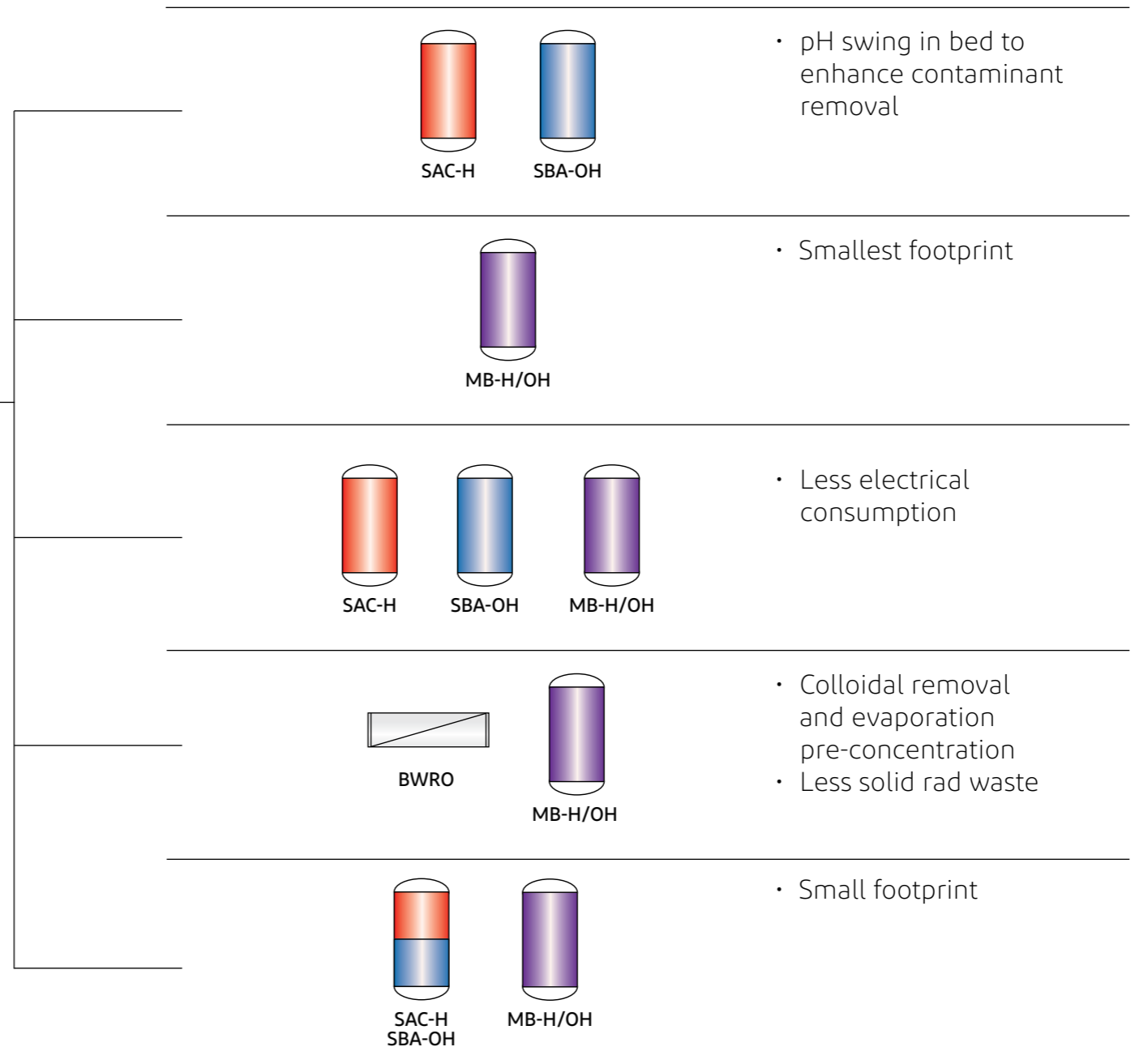

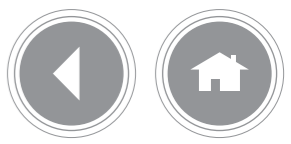

Reverse Osmosis (RO)

Filtration technology that can help to up-concentrate rad waste streams for more cost efficient disposal.

DuPont Unique: Recognized world leader in RO and NF technologies.

Benefits:

- Concentrate the radioactive waste ahead of final evaporation, reducing the waste volume and chemical consumption requirements associated with ion exchange resins in this application

The Numbers:

- A reverse osmosis system operating at typical recoveries can reduce the volume of downstream evaporation by as much as 75% or more

BACK

RECOMMENDED
PRODUCTS

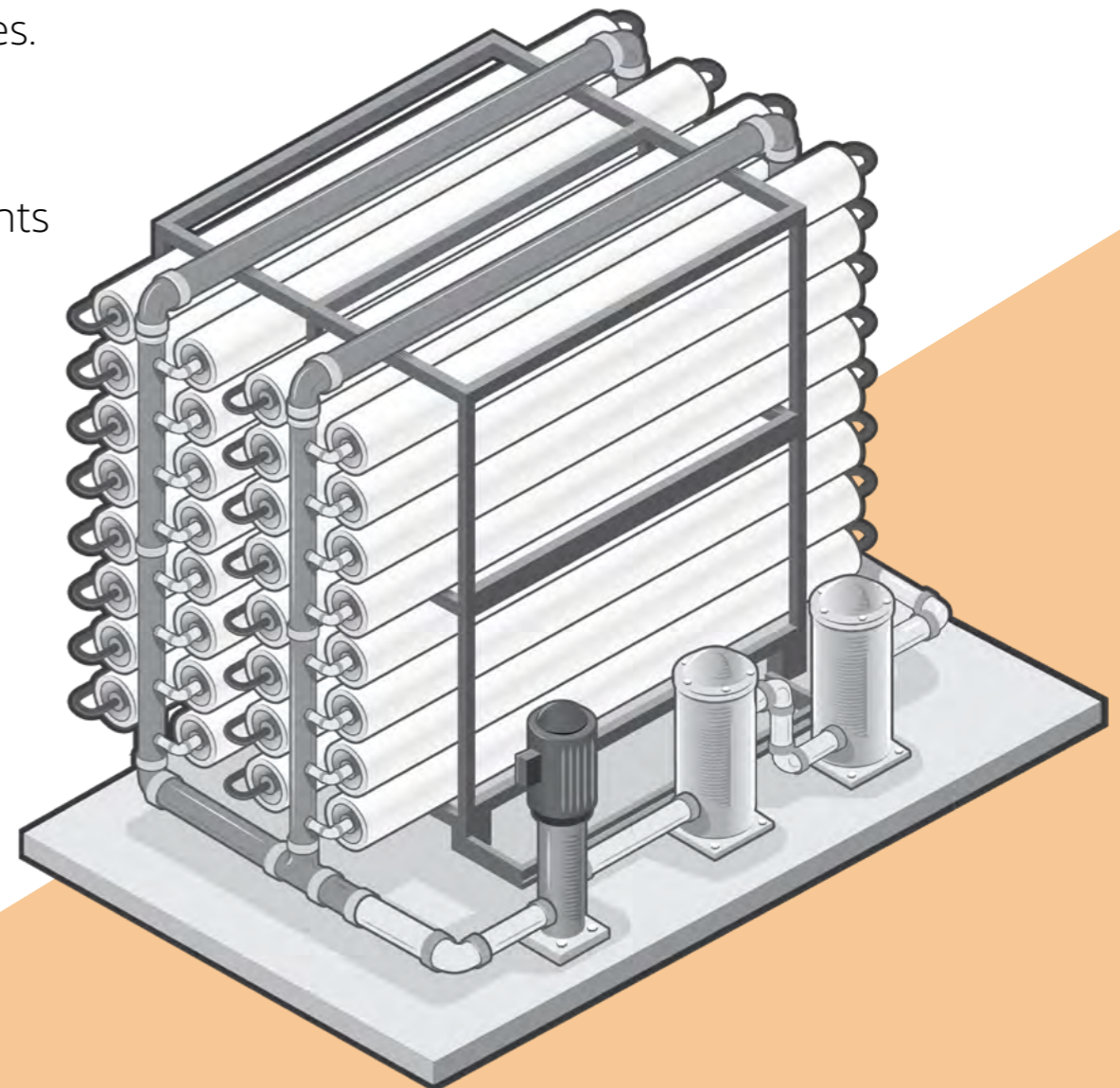

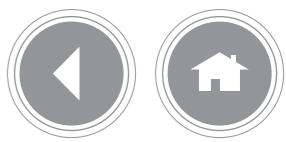

Ion Exchange (IX)

Purification technology that removes residual contaminants and radioactive species dissolved at trace levels.

DuPont Unique: Recognized world-leading ion exchange brands offer superior strength and quality. DuPont offers a comprehensive range of ion exchange resins to suit the most stringent water purity requirements and operating parameters.

Benefits:

- Great balance between performance, efficiency and lifetime
- Gain higher operating capacity when using separate SAC and SBA beds before a polisher compared to a mixed bed
- Separate beds also impart wide pH swings on the water during treatment, sometimes helping to ionize and dissolve colloidal material, such as radioactive species, for subsequent removal

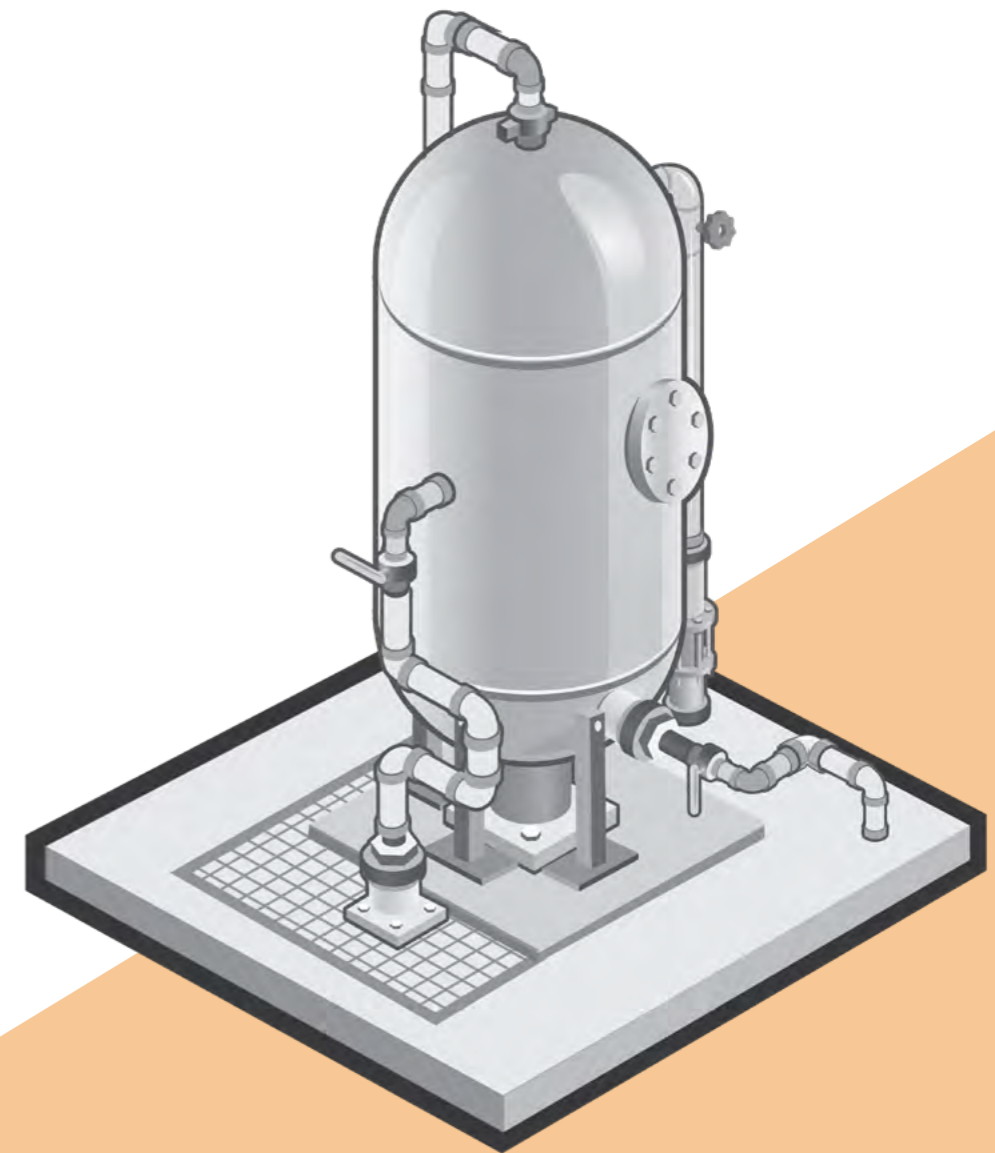
[BACK](#)[RECOMMENDED PRODUCTS](#)

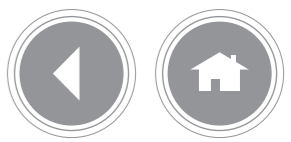

Ion Exchange Mixed Bed (IX MB)

Purification technology ideal to remove residual contaminants and radioactive species dissolved at trace levels.

DuPont Unique: Recognized world-leading ion exchange brands offer superior strength and quality for high performance polishing MB applications.

Benefits:

- Great balance between performance, efficiency and lifetime with uniform particle sizes to minimize pressure drop
- Removes trace radioactive species, allowing for wastewater reuse or discharge
- The final step to remove all traces of contaminants, in most cases
- The optimum resin configuration depends greatly on the constituents of the rad waste water. DuPont has multiple resin offerings to tailor a solution to fit your needs.

The Numbers:

- Increase MB lifetime by as much as 10% with high operating capacity resins selectively tailored toward the contaminants present

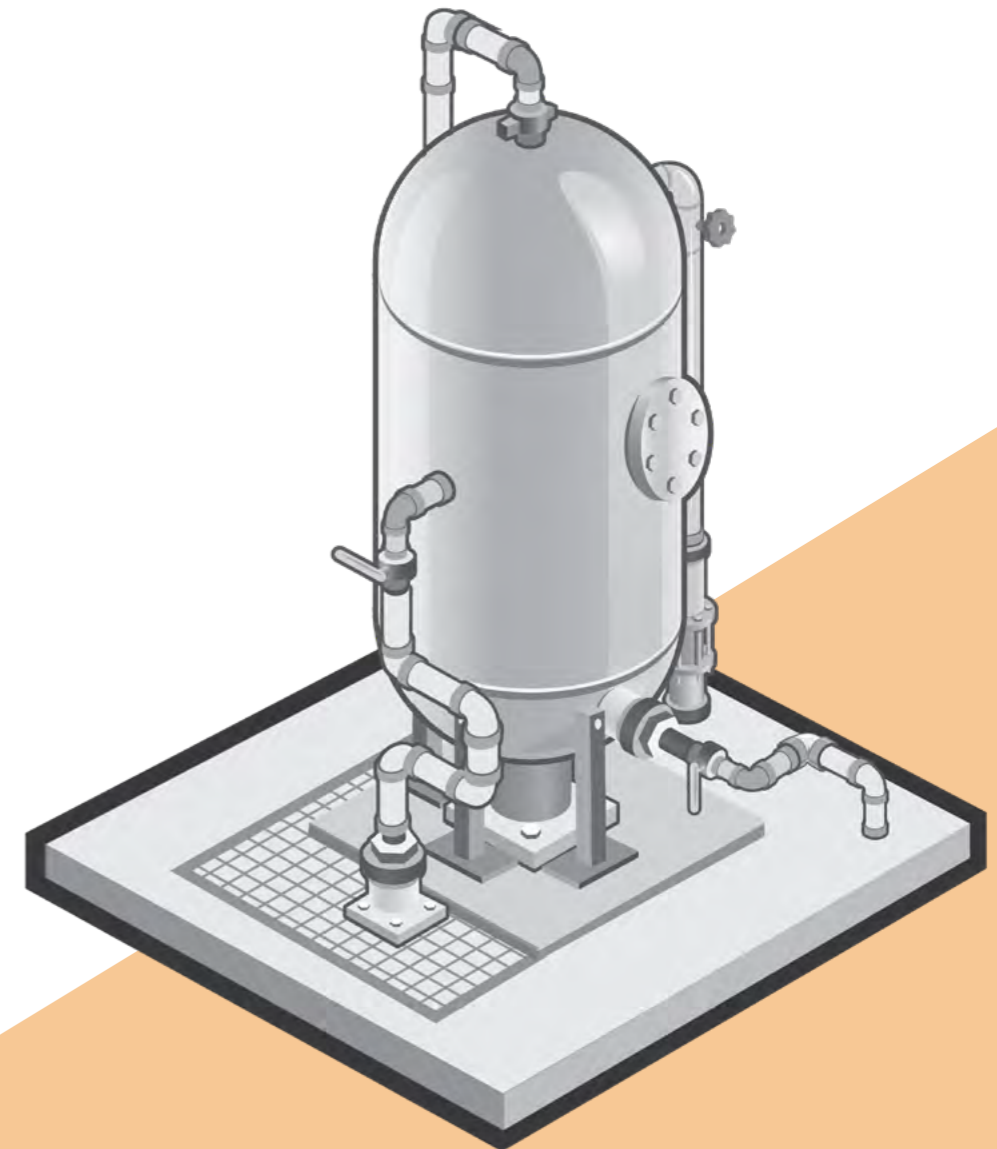

BACK

RECOMMENDED
PRODUCTS

Cool to the core.

Help ensure the quality and clarity of reactor water using IX technologies.

SEE HOW

COMMON DESIGNS

RECOMMENDED PRODUCTS

Click on **technologies** to better understand their role in water treatment.

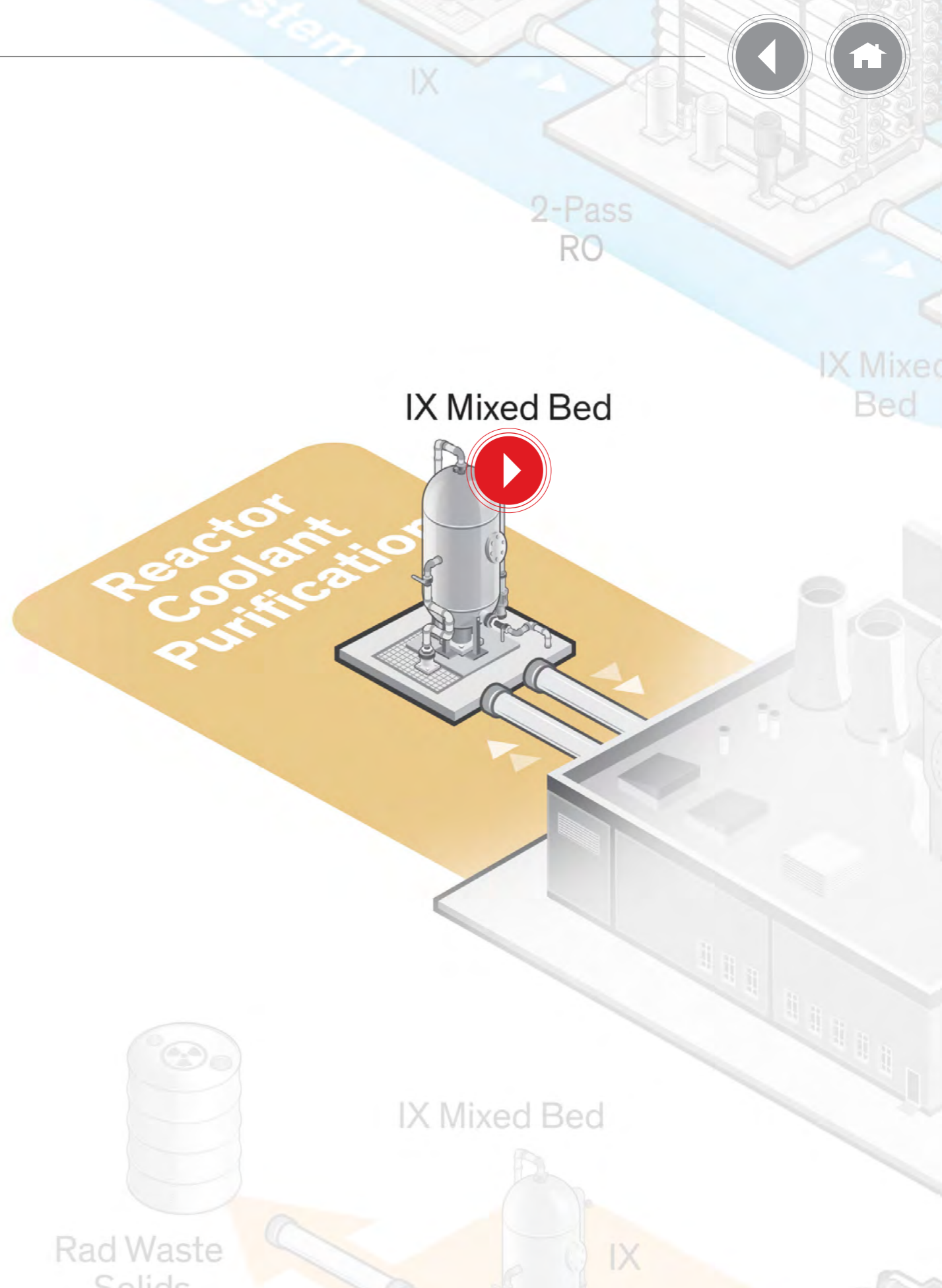



NUCLEAR POWER PLANT WATER TREATMENT • REACTOR COOLANT PURIFICATION

THE CHALLENGE



The reactor coolant water must be purged and purified to remove built up concentrations of radioisotopes, ions and corrosion products. Treated water is typically mixed with condensate for return to the reactor. IX resins used here are not regenerated and must have high purity, stability and capacity.

THE SOLUTION



Non-regenerable mixed beds or powdered ion exchange resins are used in their fully regenerated H/OH form. Once exhausted they are disposed of, since they are generally radioactive. DuPont's nuclear grade mixed bed resins have the highest loading capacity and highest oxidative stability of any nuclear grade ion exchange resin available. DuPont's manufacturing and low chloride regeneration processes result in the lowest chloride content and highest purity resins in the nuclear power industry.

BACK

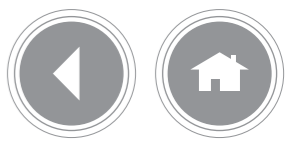

Common Designs

An ion exchange mixed bed is the standard technology for purification of reactor coolant in BWR nuclear plants.



Powder
MB-H/OH

- Most common design
- Enhanced filtration and colloidal removal



MB-H/OH

- Alternative design

BACK



CONTACT
AN EXPERT

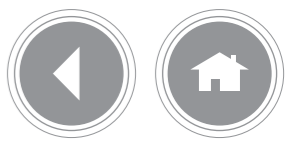

Ion Exchange Mixed Bed (IX MB)

Purification technology ideal to remove residual contaminants and radioactive species dissolved at trace levels.

DuPont Unique: Recognized world-leading ion exchange brands offer superior strength and quality for high performance polishing MB applications.

Benefits:

- Great balance between performance, efficiency and lifetime with uniform particle sizes to minimize pressure drop, removing trace radioactive species in the reactor coolant water
- The most effective technology used to purify reactor coolant water
- Further enhance colloidal removal of radioactive species by using specialized macroporous resins layered on top of the MB

The Numbers:

- Increase MB lifetime by as much as 10% with high operating capacity resins and the addition of a colloidal removal layer

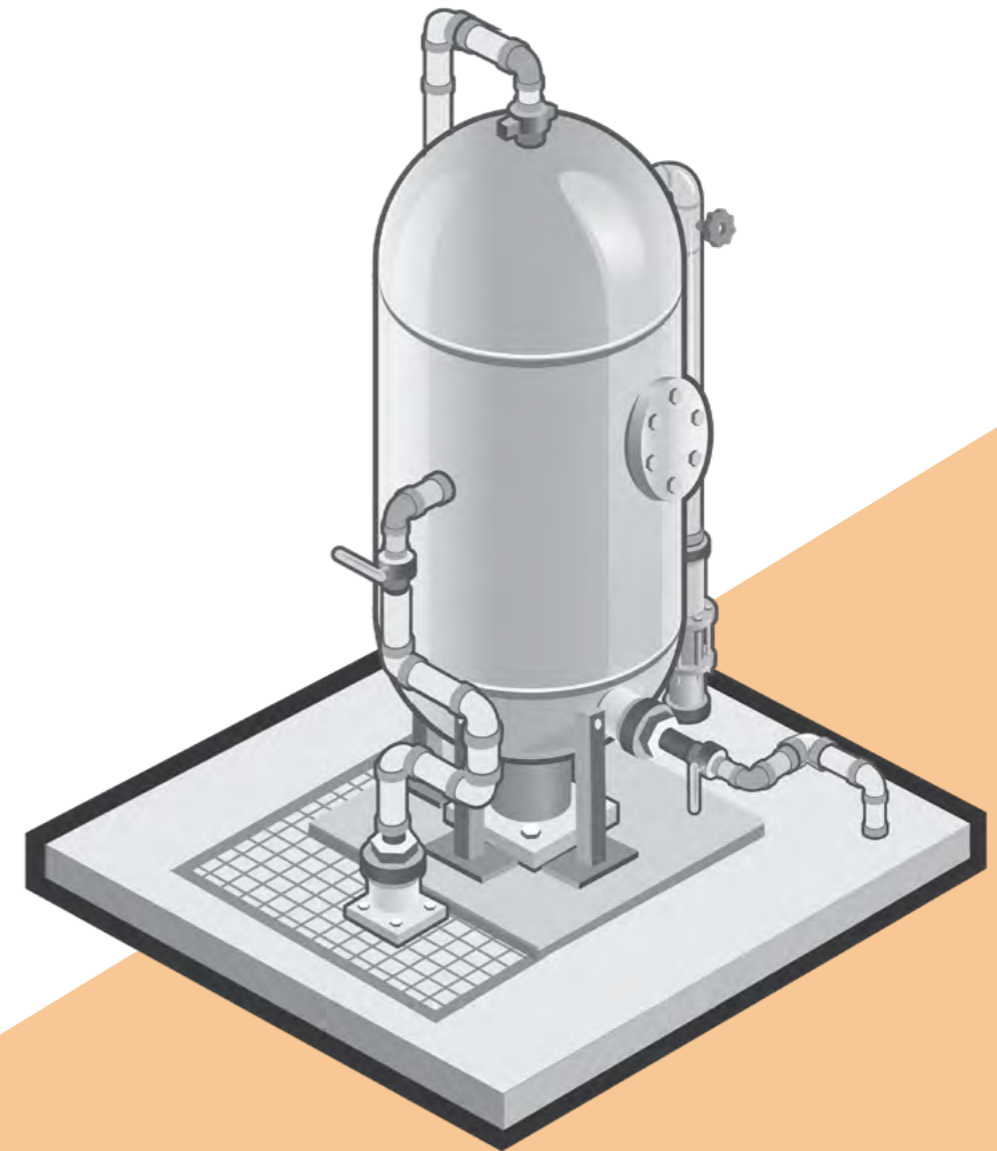
[BACK](#)[RECOMMENDED PRODUCTS](#)



A shield of clean water.

Help ensure the quality and clarity of spent fuel pool water using IX technologies.

SEE HOW

COMMON DESIGNS

RECOMMENDED PRODUCTS

Click on technologies to better understand their role in water treatment.

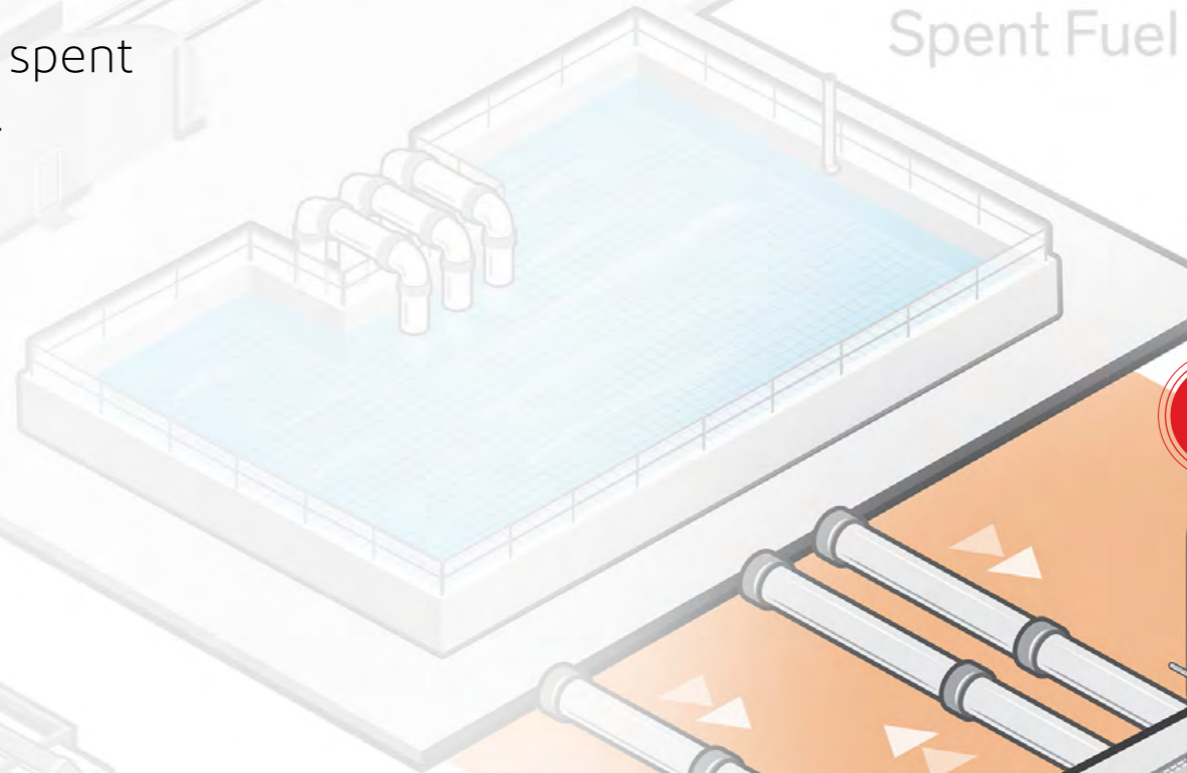

IX



IX Mixed Bed

Spent Fuel Pool Purification

RO

A shield of clean water

Help e
fuel po



NUCLEAR POWER PLANT WATER TREATMENT • SPENT FUEL POOL PURIFICATION

THE CHALLENGE



Nuclear fuel is handled and stored under water for safety. The quality and clarity of this water is important to limit radiation exposure to workers, minimize corrosion of fuel cladding, improve visibility when manipulating rods, and prevent reactor contamination during refueling. For these reasons, fuel pool clean-up systems are employed. The resins used here must be oxidatively stable to the low levels of peroxide formed by radiolysis of the fuel pool water.

THE SOLUTION



Non-regenerable mixed beds or powders are used in their fully regenerated H/OH form. Once exhausted they are disposed of, since they are generally radioactive. Macroporous resins are offered where fouling and pressure drop are of concern. Regenerable designs using separate cation and anion beds are also available. DuPont's nuclear grade mixed bed resins have high oxidative stability and the highest loading capacity of any nuclear grade IX resin available.

Click o
unders

ed Bed
Pool
ation

BACK

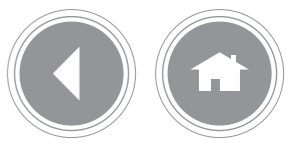

Common Designs

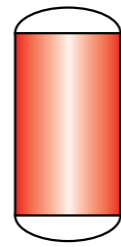

SAC-H

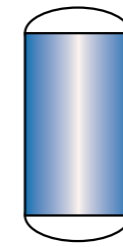

SBA-OH

- Regenerable designs

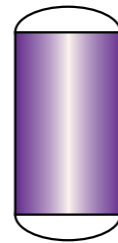

MB-H/OH

- Better purity and higher exchange capacity

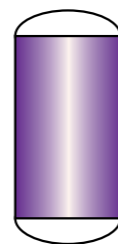

Powder
MB-H/OH

- Enhanced filtration and colloidal removal

BACK

 CONTACT
AN EXPERT

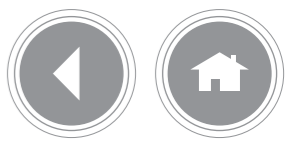

Ion Exchange (IX)

Purification technology that removes residual contaminants and radioactive species dissolved at trace levels.

DuPont Unique: Recognized world-leading ion exchange brands offer superior strength and quality. DuPont offers a comprehensive range of ion exchange resins to suit the most stringent water purity requirements and operating parameters.

Benefits:

- Great balance between performance, efficiency and lifetime
- Separate beds of strong acid cation and strong base anion are in certain designs to allow for high cation operating capacity and regeneration of the resins

The Numbers:

- Improve stability in the oxidative spent fuel pool environment (5-6 ppm H_2O_2), lower baseline SO_4 levels, minimize SO_4 spikes and increase bed life by up to 10-40% when using high cross-linked gel cation resins

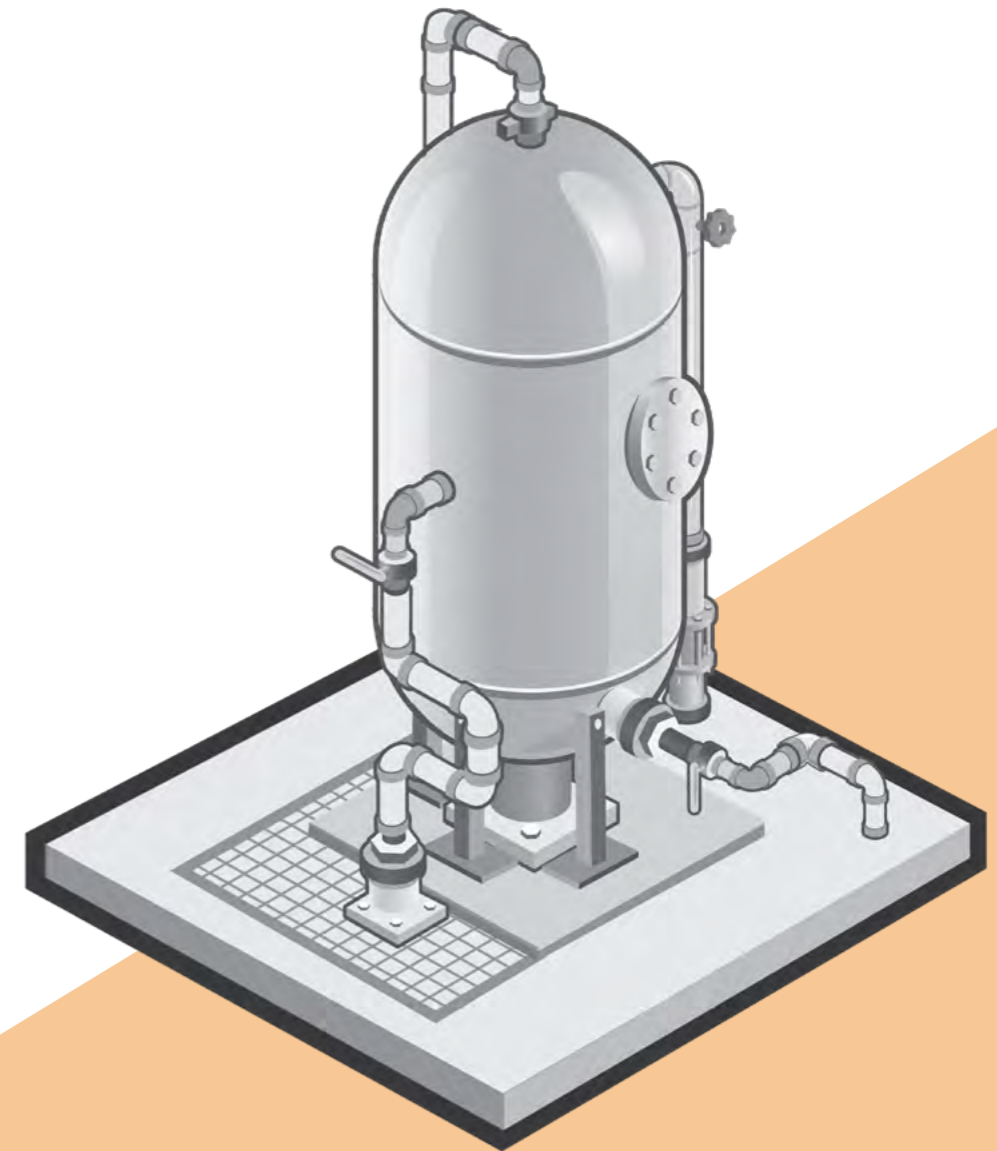
[BACK](#)[RECOMMENDED PRODUCTS](#)

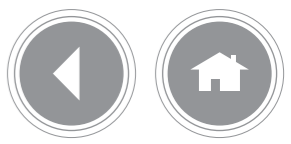

Ion Exchange Mixed Bed (IX MB)

Purification technology ideal for low TDS conditions to remove residual contaminants typically present in the low ppm to ppb range.

DuPont Unique: Recognized world-leading ion exchange brands offer superior strength and quality for high performance polishing MB applications.

Benefits:

- Effectively remove radioactivity and suspended solids at high throughput
- High capacities maximize bed life and minimize rad waste disposal cost
- Enhance kinetics or remove colloidal material by using macroporous resins in the MB or as layers on top

The Numbers:

- Produce as much as a 10% increase in operating throughput when using resins with highest exchange capacity
- Improve stability in the oxidative environment (5-6 ppm H_2O_2), lower baseline SO_4 levels by 10-20 times and increase bed life by up to 40% with nuclear grade 16% DVB gel cation resins

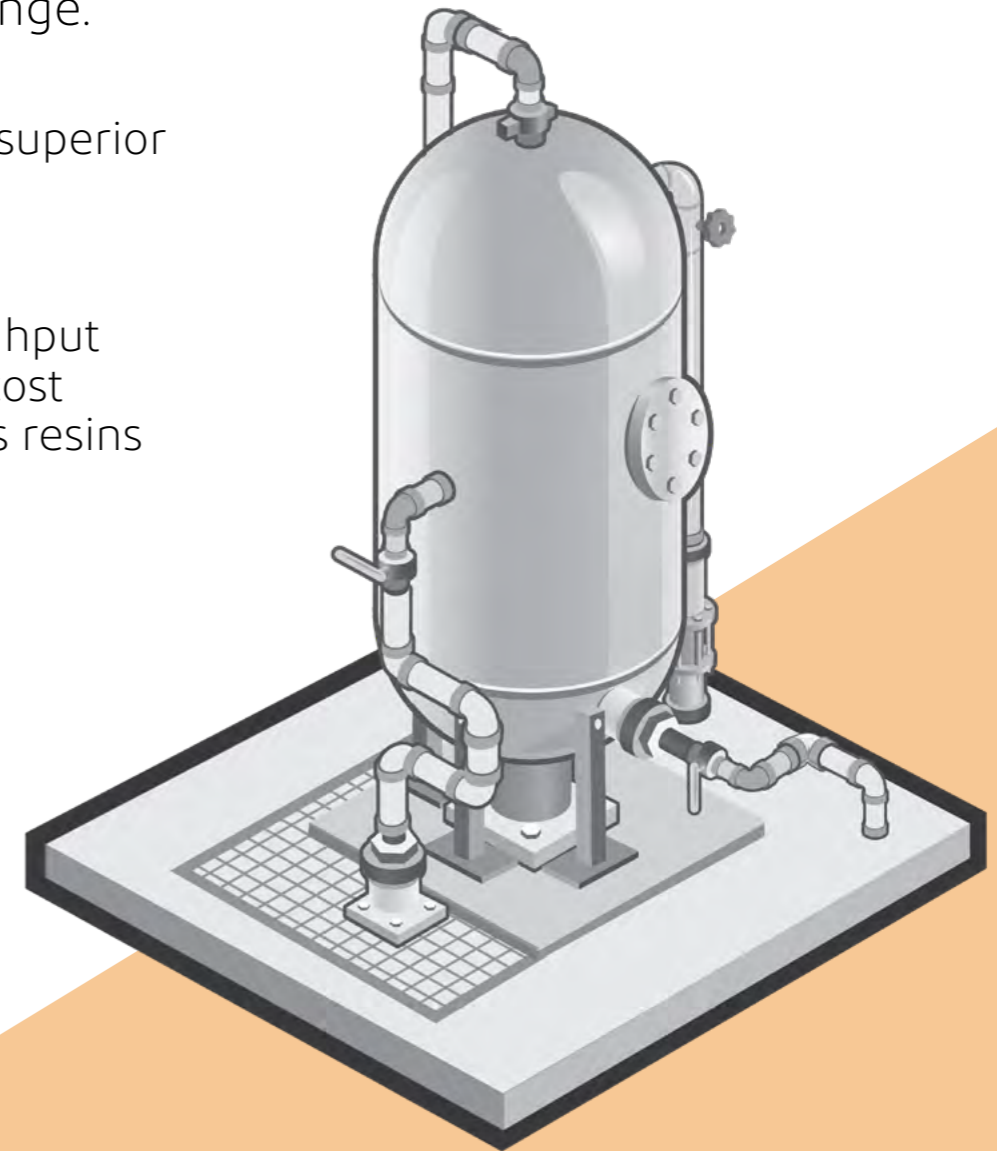
[BACK](#)[RECOMMENDED PRODUCTS](#)



A cool generator is a happy generator.

Prevent corrosion of stator bars to help prevent failure of the generator.

SEE HOW

COMMON DESIGNS

RECOMMENDED PRODUCTS

Click on technologies to better understand their role in stator cooling water treatment.



Spent Fuel

Turbine

Generator

IX Mixed Bed

IX

IX Mixed Bed

Stator Cooling Treatment

Condensate Polishing Plant



NUCLEAR POWER PLANT WATER TREATMENT • STATOR COOLING TREATMENT

THE CHALLENGE



Stator bar overheating puts an electric generator at risk of reduced efficiency or even total failure. The temperature of the bars is maintained by a closed loop cooling water circuit, which is susceptible to both corrosion and particulate fouling, for example from copper oxides. Management of copper corrosion requires highly deionized cooling water and precise management of pH and oxygen levels.

THE SOLUTION



The stator cooling system is operated at neutral or elevated pH with either low or high oxygen levels to minimize copper corrosion. A mixed bed polisher removes both particulates and ions introduced into the loop through makeup and corrosion. An alkaline pH can be maintained by treating a portion of the circuit with a sodium form polishing bed.

BACK

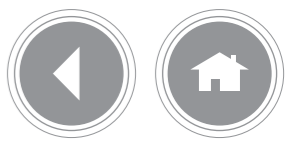

Common Designs

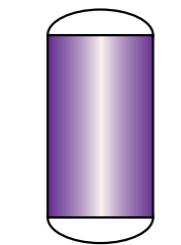

MB-H/OH

- Standard design, circuit purification

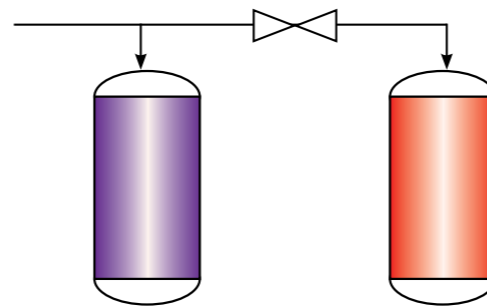

MB-H/OH

SAC-H

- Additional pH control to dissolve copper

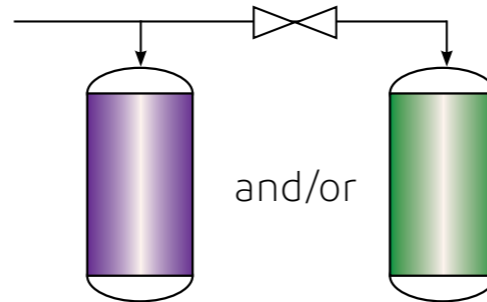

MB-H/OH

MB-Na/OH

and/or

- Circuit purification
- Na form cation resin for maintaining alkaline pH

BACK

CONTACT AN EXPERT



Ion Exchange (IX)

Purification technology that removes residual contaminants at low levels.

DuPont Unique: Recognized world-leading ion exchange brands offer superior strength and quality for high performance applications. DuPont offers a comprehensive range of uniform particle size ion exchange resins to suit the most stringent water purity and operating parameters.

Benefits:

- Control the pH of the stator water through the optional use of a hydrogen form cation resin, allowing for the dissolution and removal of copper oxide to enhance heat transfer in the stator circuit
- Great balance between performance, efficiency and lifetime

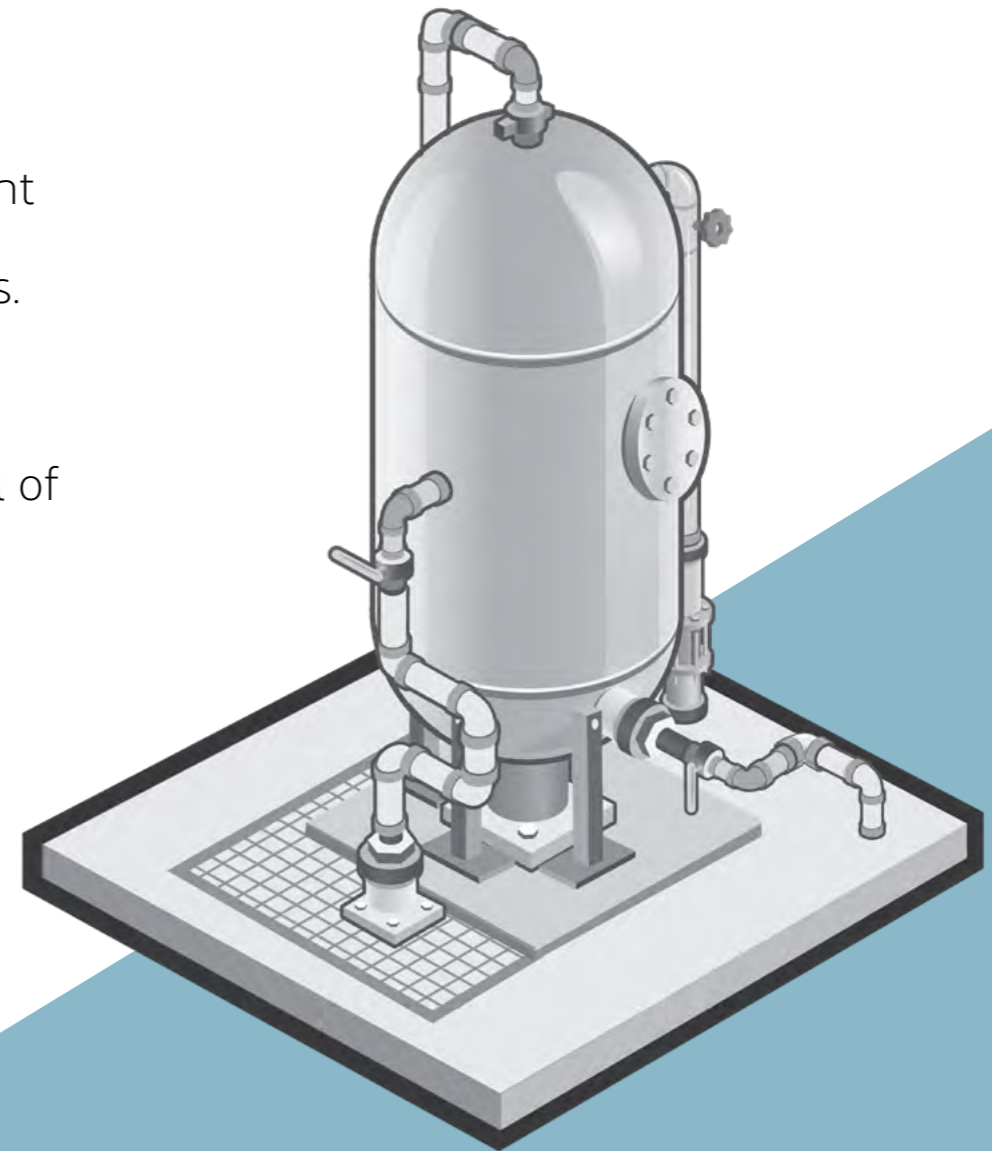
[BACK](#)[RECOMMENDED PRODUCTS](#)

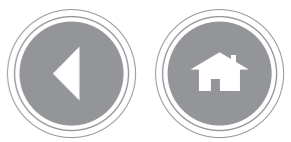

Ion Exchange Mixed Bed (IX MB)

Purification technology ideal for low TDS conditions to remove residual contaminants typically present in the low ppm to ppb range.

DuPont Unique: Recognized world-leading ion exchange brands offer superior strength and quality for high performance polishing MB applications.

Benefits:

- The most effective technology used to deionize stator cooling water
- Great balance between performance, stability, efficiency and lifetime, with uniform particle size resins that minimize pressure drop while optimizing separation for effective regeneration
- Elevate the stator water pH to prevent copper corrosion through use of a Na/OH form MB

The Numbers:

- Triple the lifetime of this MB and reduce the risk of premature or unexpected breakthrough when using the proper configuration with a high DVB cation resin

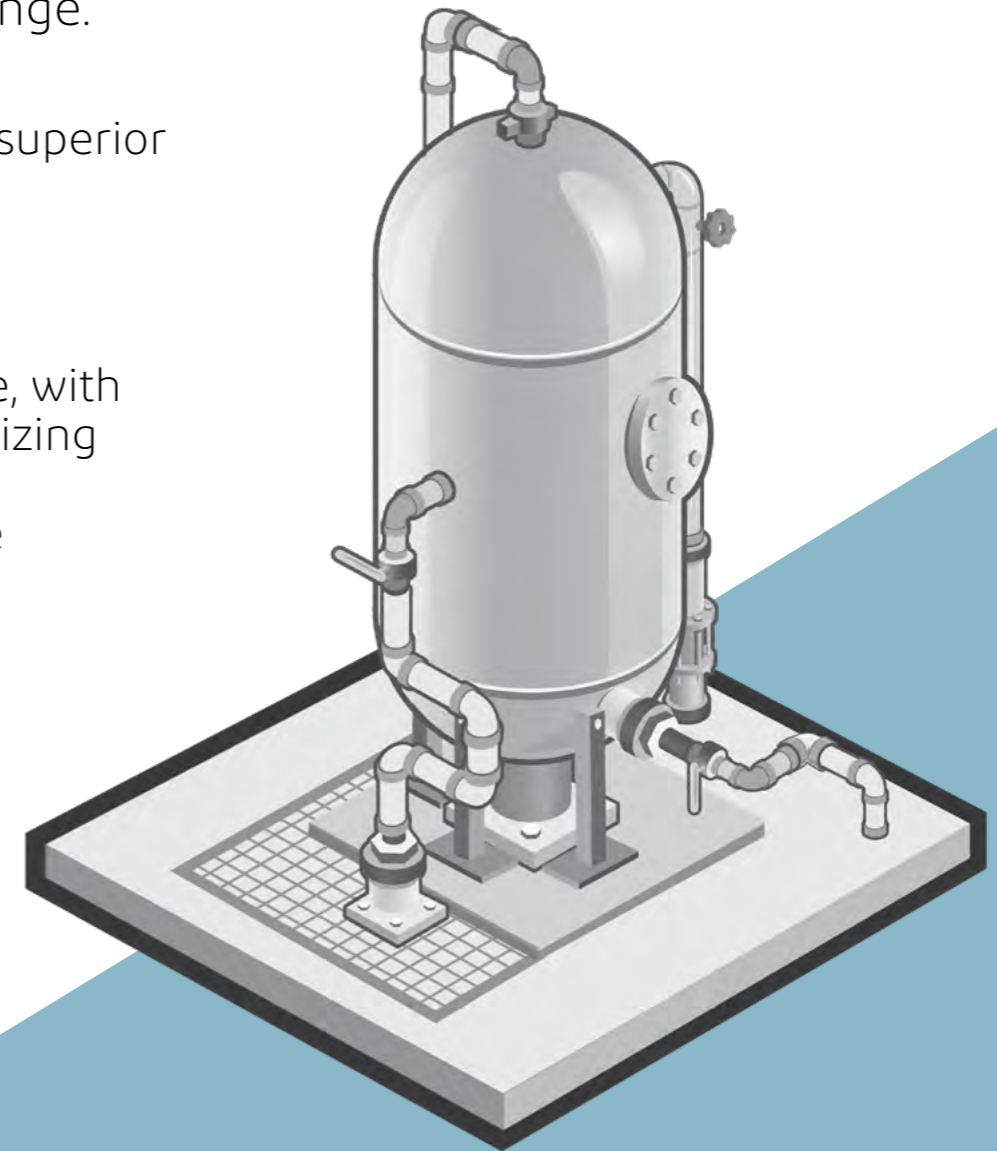

BACK

RECOMMENDED
PRODUCTS

Keep your circuit clean and protected.

Remove trace contaminants and protect against condenser leaks.

SEE HOW

COMMON DESIGNS

RECOMMENDED PRODUCTS

Click on technologies to better understand their role in condensate polishing treatment.

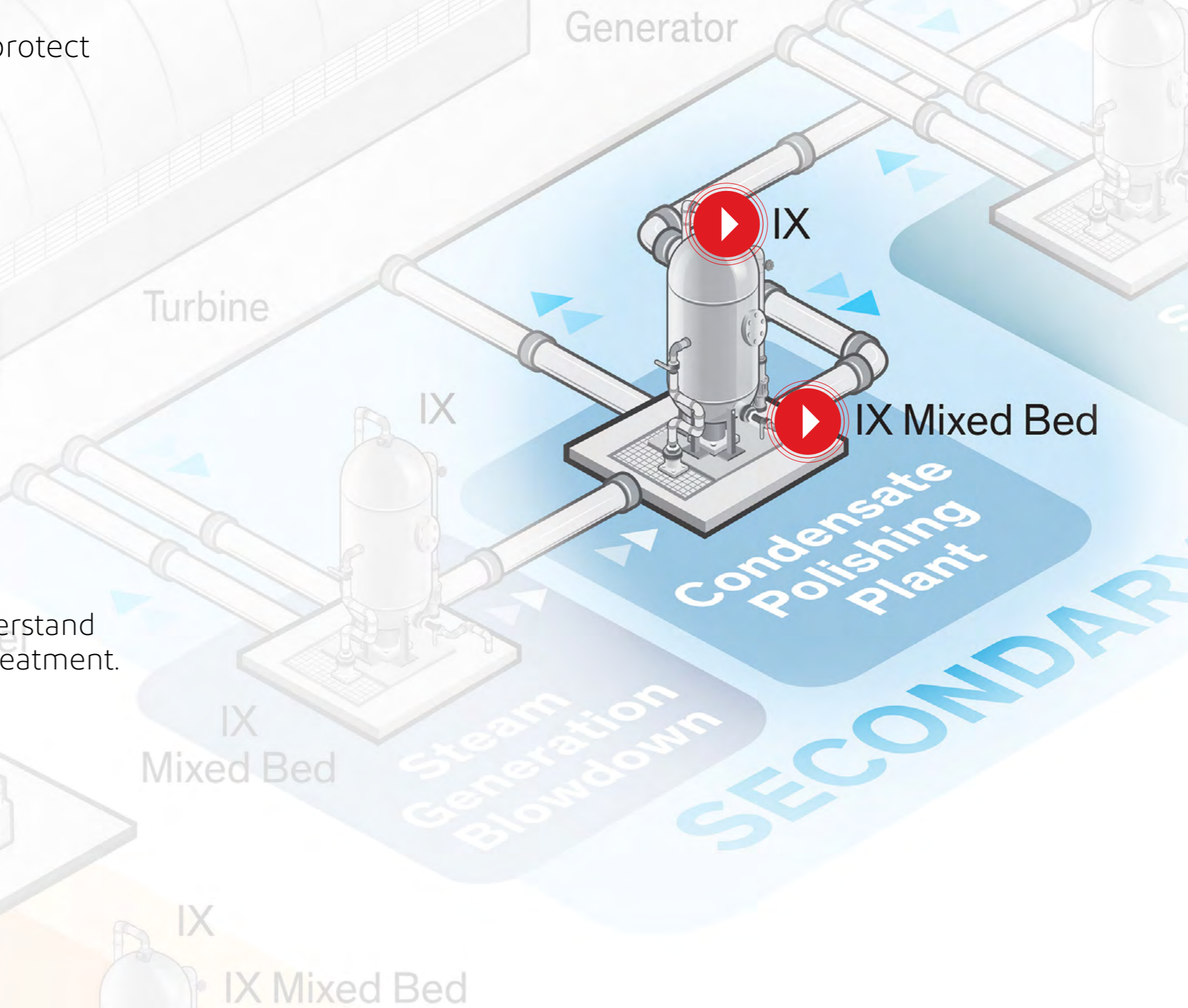



Keep your circuit clean and protected



NUCLEAR POWER PLANT WATER TREATMENT • CONDENSATE POLISHING

THE CHALLENGE



The secondary circuit in PWR designs must be maintained at a high purity to prevent corrosion and protect against condenser leaks. Amines added for corrosion control are also removed by the condensate polishing plant. High amine capacity is desired to reduce regeneration frequency and keep operating costs low. The polishing plant must be optimized to the unique needs of each facility, as reactor design and amine chemistry can vary considerably from site to site.

THE SOLUTION



Ion exchange condensate polishers protect critical power plant components and improve plant reliability. Regardless of the engineering design employed, the system is only as good as the ion exchange resins used. DuPont resins used in condensate polishing have been protecting valuable power plant assets and improving reliability throughout the world for decades. DuPont's portfolio of resins has several offerings specifically tailored to meet the challenging demands of PWR condensate polishing.

BACK

Remov
again

Click o
their r

Bed

ARI

IX Mixed Bed

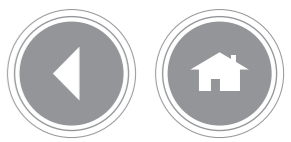

Common Designs

A variety of schemes using ion exchange resins can be found in PWR condensate polishing.

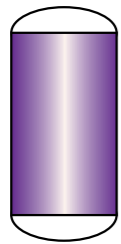

MB-H/OH

- Most common



MB-H/OH

- Mobile or fixed condensate polisher used for startup purification

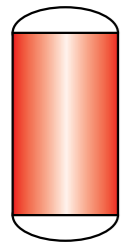

SAC-H

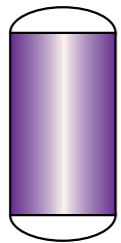

MB-H/OH

- New facilities with high amine loadings, looking to increase MB lifetime



Powder
MB-H/OH

- Alternative with improved filtration

BACK

CONTACT AN EXPERT

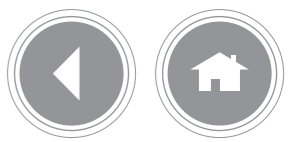

Ion Exchange (IX)

Purification technology ideal to remove residual contaminants typically present in the low ppm to ppb range.

DuPont Unique: Recognized world-leading ion exchange brands offer superior strength and quality. DuPont offers a comprehensive range of ion exchange resins to suit the most stringent water purity requirements and operating parameters.

Benefits:

- Continue purification of the condensed steam and protect against condenser leaks
- Increase lifetime of MB condensate polishing systems by pretreatment with a strong acid cation bed to remove amines
- Great balance between performance, efficiency and lifetime

The Numbers:

- 20-30% longer run time and reduce corrosion during operation with high capacity gel cation resin for condensate polishing

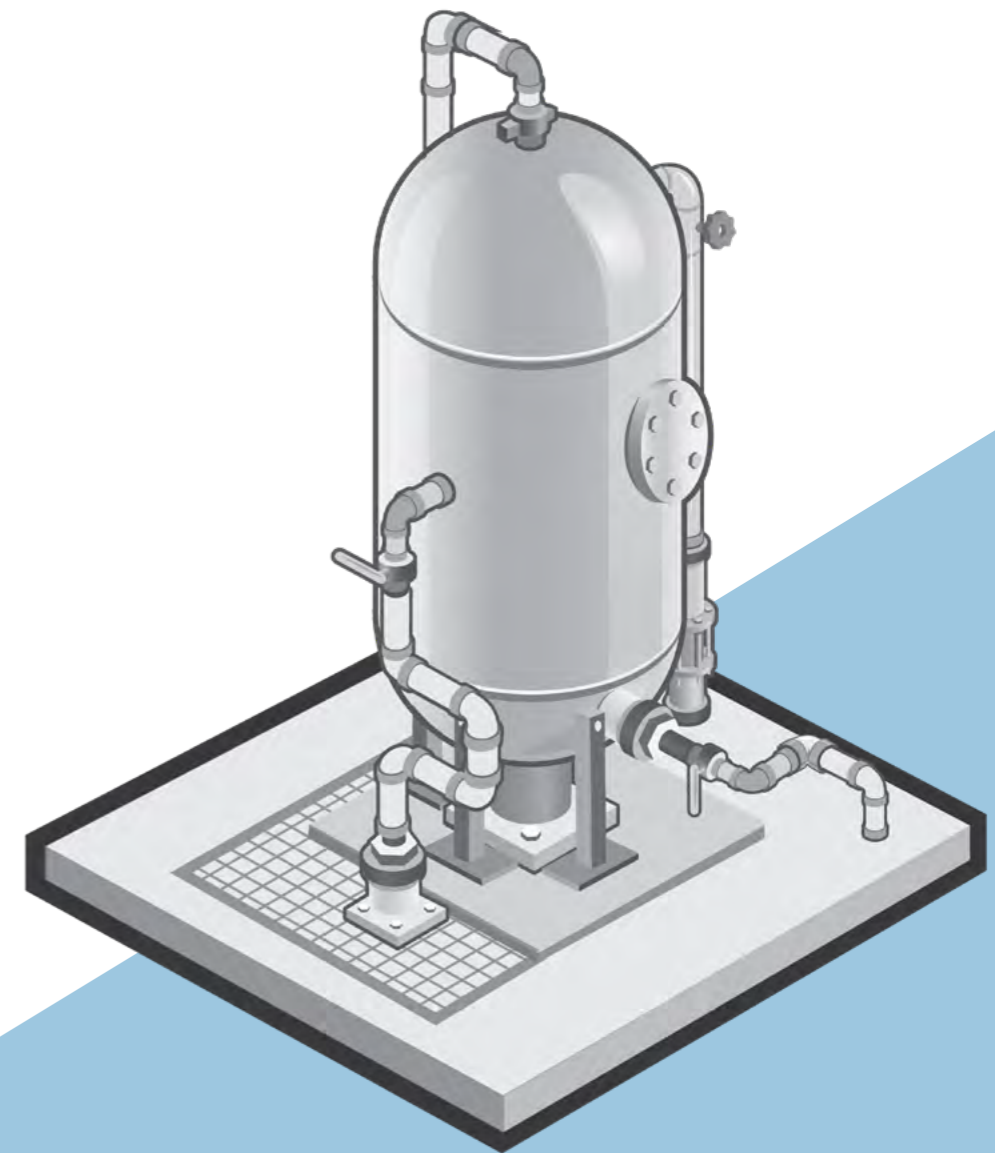
[BACK](#)[RECOMMENDED PRODUCTS](#)

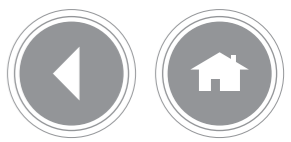

Ion Exchange Mixed Bed (IX MB)

Purification technology ideal to remove residual contaminants typically present in the low ppm to ppb range. IX MB is the standard for steam condensate treatment.

DuPont Unique: Recognized world-leading IX brands offer superior strength and quality for high performance in working and polishing MB applications.

Benefits:

- Great combination of trace contaminant removal, oxidative stability, capacity and operational life
- Premium UPS gel/gel pair is engineered for low pressure drop, outstanding separation during regeneration, and long resin life
- Macroreticular anion resins provide high anion kinetics, excellent resistance to surface fouling and high osmotic stability
- A specially formulated cation resin minimizes anion kinetic degradation associated with ethanolamine

The Numbers:

- 20-30% longer run time and reduced corrosion during operation with DuPont's high capacity gel cation
- Improve fouling resistance with a specially formulated macroporous anion resin

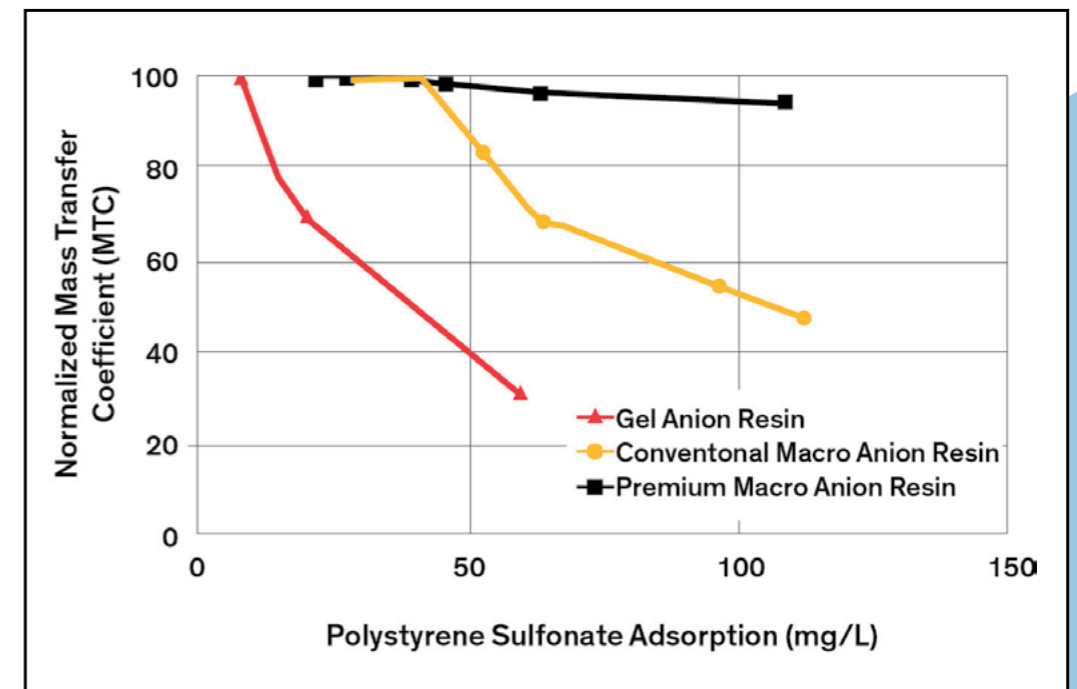

T. Ito, et al. A Quantum Leap in CPP Ion Exchange Resin Technology, 62nd International Water Conference, Pittsburgh, 2001.

BACK

RECOMMENDED
PRODUCTS



Stability and control are on your side.

Maintain the quality and purity of reactor coolant water in a nuclear environment.

SEE HOW

COMMON DESIGNS

RECOMMENDED PRODUCTS

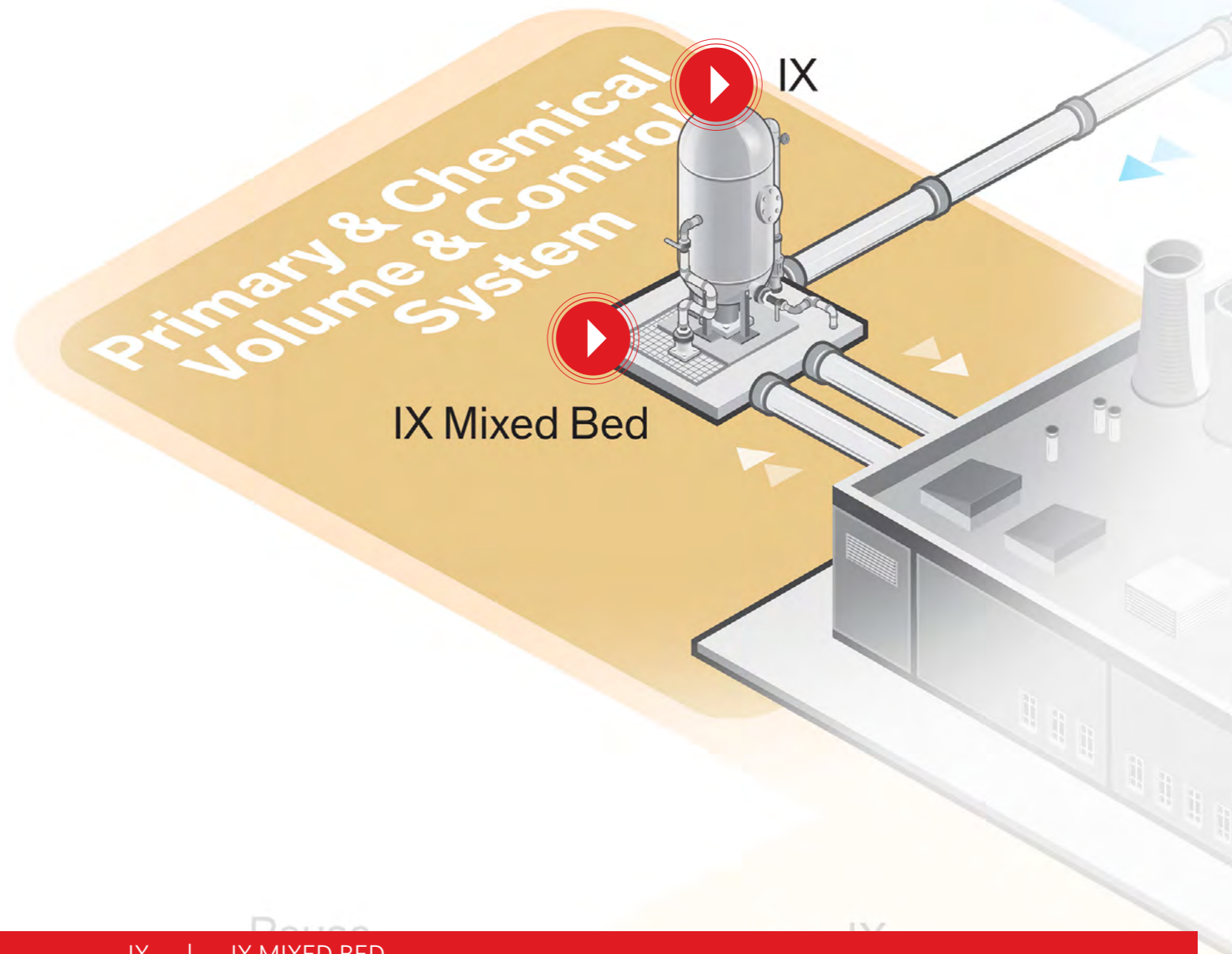

Click on **technologies** to better understand their role in CVCS water treatment.



Stability and control are on your side



NUCLEAR POWER PLANT WATER TREATMENT • PRIMARY AND CHEMICAL VOLUME CONTROL SYSTEM (CVCS)

THE CHALLENGE



The primary loop carries heat from the reactor core to steam generators. The water chemistry employs neutron moderators and pH control agents which, in most designs, are boric acid and lithium-7 hydroxide, respectively. Control of impurities, suspended solids and radioactive matter is absolutely vital, and is carried out by the chemical and volumetric control system (CVCS), which operates on a side stream of the reactor coolant loop. IX resins used here are non-regenerable and must have high purity, stability and capacity.

THE SOLUTION



DuPont's nuclear grade resins have proven to be the premier resins chosen to protect nuclear power plants throughout the world. DuPont's low chloride regeneration process results in the lowest chloride content and highest purity resins in the nuclear power industry. These resins offer the highest oxidative stability and highest loading capacity of any nuclear grade ion exchange resin available in the industry.

BACK

Maintain
coolant

Click on
their re

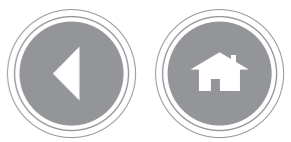

Common Designs

Ion exchange resins are used in several ways within the primary nuclear loop to manage pH and neutron moderators as well as remove contaminants.

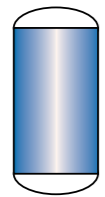

SBA-OH

- Boron removal



MB-H/OH

- On-line shimming for pH control
- End of cycle cation removal

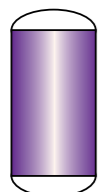

MB-⁷Li/OH

or

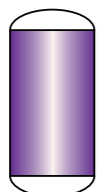

MB-H/OH

- Reactor coolant purification (removal of radioisotopes & other contaminants)
- pH control

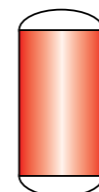

SAC-H

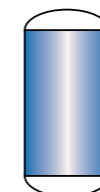

SBA-OH

- Boron recovery in certain specific designs

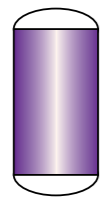

MB-H/OH

- Outage purification

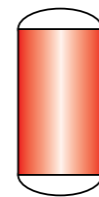

SAC-H



MB-H/OH

- Primary effluent blowdown treatment for reuse or disposal

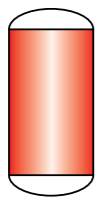

SAC-H

- On-line shimming for pH control
- End of cycle cation removal

BACK



CONTACT AN EXPERT



Ion Exchange (IX)

Purification technology ideal to remove residual contaminants typically present in the low ppm to ppb range.

DuPont Unique: Recognized world-leading ion exchange brands offer superior strength, purity and quality.

Benefits:

- Great balance between performance, efficiency and lifetime
- Control boron levels in the circuit and capture and recover boron for reuse when a hydroxide form strong base anion resin treats a portion of the CVCS stream
- Control pH with a hydrogen form strong acid cation resin by shimming lithium or other cations from the circuit, and at the end of operational cycles to remove all cations from the system

The Numbers:

- Receive 30% higher boron removal capacity with DuPont's high capacity nuclear grade anion resin compared to conventional ion exchange resins

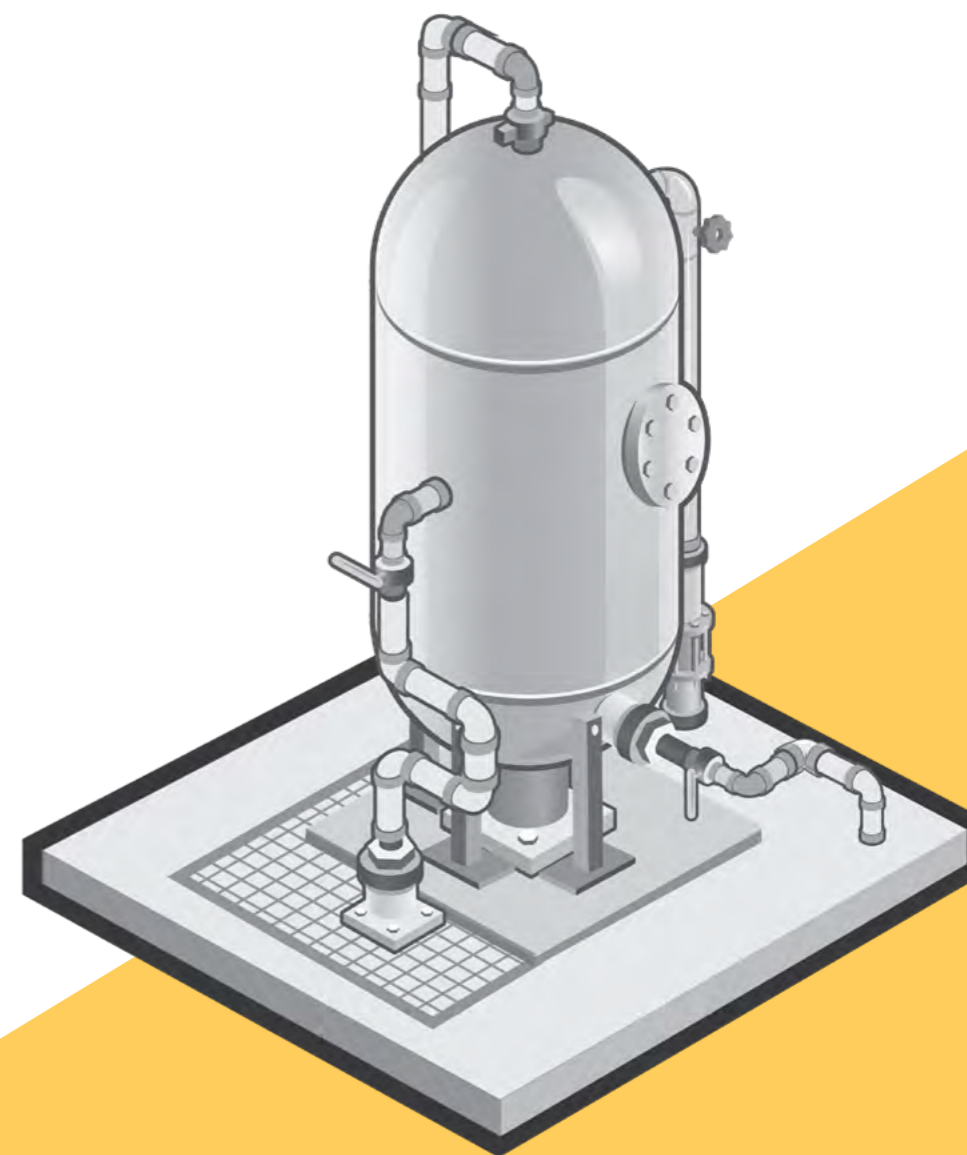
[BACK](#)[RECOMMENDED PRODUCTS](#)

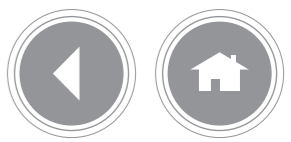

Ion Exchange Mixed Bed (IX MB)

Purification technology ideal to remove residual contaminants typically present in the low ppm to ppb range. IX MB is an essential component of primary side water treatment.

DuPont Unique: Recognized world-leading ion exchange brands offer superior strength, purity and quality for high performance polishing MB applications.

Benefits:

- Removes radioisotopes (e.g., ^{137}Cs , ^{58}Co , ^{131}I) and other contaminants (e.g., Cl , SO_4) from the primary coolant and maintains the LiOH pH buffer
- Manages system outages and purifies primary effluent or blowdown
- Significantly lower reactor sulfate levels by using a highly crosslinked cation resin that delivers the highest total capacity and best chemical and oxidative stability of any available nuclear-grade resin

The Numbers:

- Increase operating lifetime by 10-20%, lower rad waste costs and decrease radiation exposure risk when using high capacity UPS resins

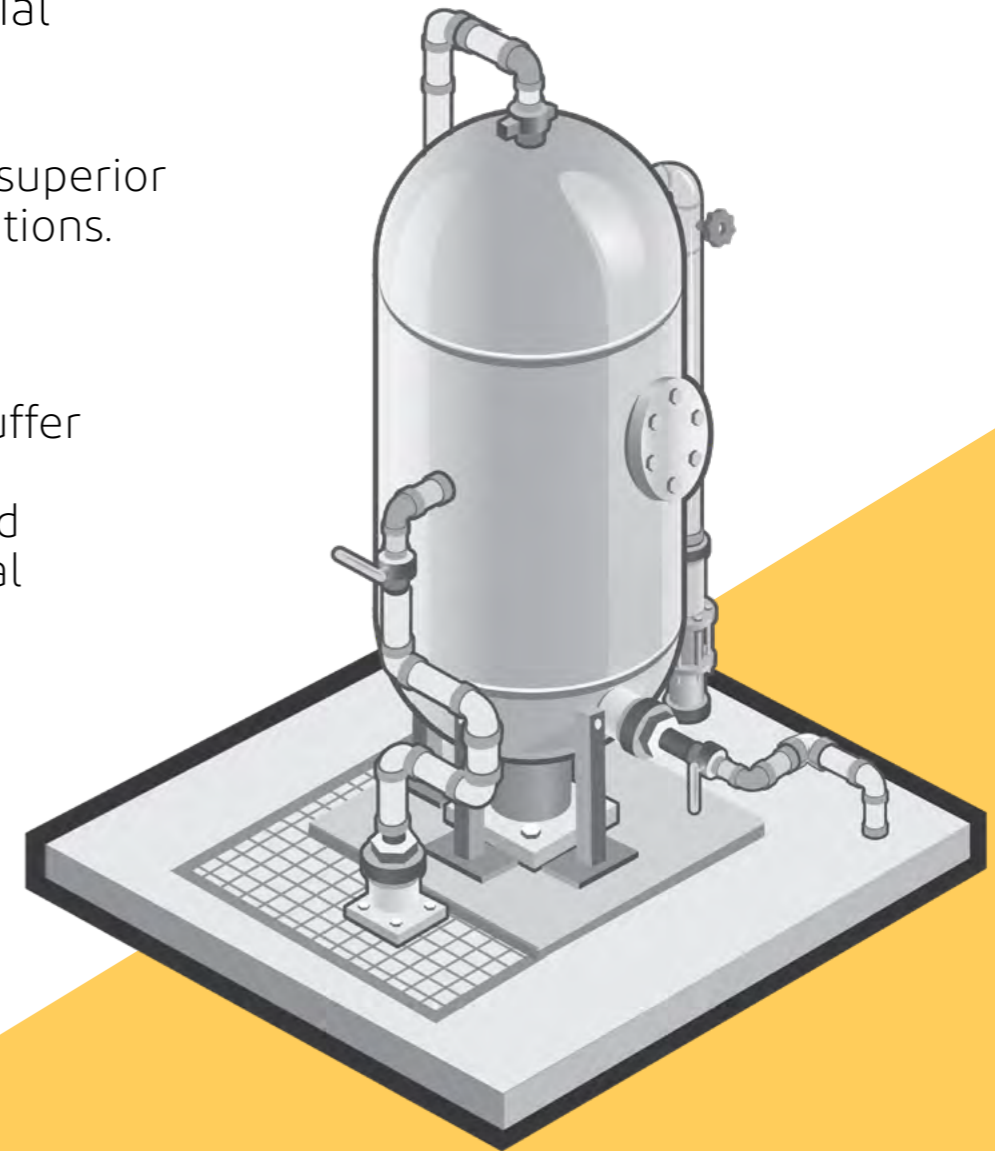
[BACK](#)[RECOMMENDED PRODUCTS](#)



Keep your circuit clean.

Remove abrasion products and ions coming from leakage of different exchangers.

SEE HOW

COMMON DESIGNS

RECOMMENDED PRODUCTS

Click on **technologies** to better understand their role in steam generation blowdown water treatment.

Turbine

Spent Fuel

IX
IX Mixed Bed

Steam Generation Blowdown

Condensate Polishing

IX
IX Mixed Bed

RO

pool



NUCLEAR POWER PLANT WATER TREATMENT • STEAM GENERATOR BLOWDOWN

THE CHALLENGE



The PWR secondary circuit must be maintained at a high purity to prevent corrosion and protect against condenser leaks. Steam generator blowdown can be purified and recycled as an alternative or in addition to the condensate polishing plant. This water has 80-200x more dissolved solids than that seen in condensate polishing. High amine capacity is desired to reduce regeneration frequency and keep operating costs low.

THE SOLUTION



Ion exchange resins protect critical power plant components and improve plant reliability. Regardless of the engineering design employed, the system is only as good as the ion exchange resins used. DuPont resins used in steam generator blowdown have been protecting valuable power plant assets and improving reliability throughout the world for decades. Our portfolio of nuclear grade resins has several offerings specifically tailored to meet the challenging demands of PWR secondary circuit purification.

BACK

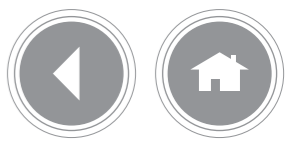

Common Designs

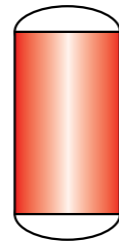

SAC-H



MB-H/OH

- New facilities with high amine loadings, looking to increase MB lifetime

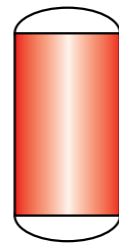

SAC-H



SBA-OH

- Established design



MB-H/OH

- Established design

BACK

 CONTACT AN EXPERT

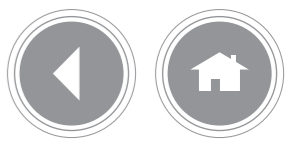

Ion Exchange (IX)

Purification technology that removes dissolved solids, total organic carbon, and silica.

DuPont Unique: Recognized world-leading ion exchange brands offer superior strength and quality. DuPont offers a comprehensive range of ion exchange resins to suit the most stringent water purity requirements and operating parameters.

Benefits:

- Using separate cation and anion beds allows for simple regeneration and replacement of exhausted resins individually, whereas a mixed bed must be replaced all at once
- Increase mixed bed lifetime in a steam generator blowdown by pre-treatment with a strong acid cation bed to remove amines

The Numbers:

- 20-30% longer run time and reduce corrosion during operation with high capacity gel cation resin

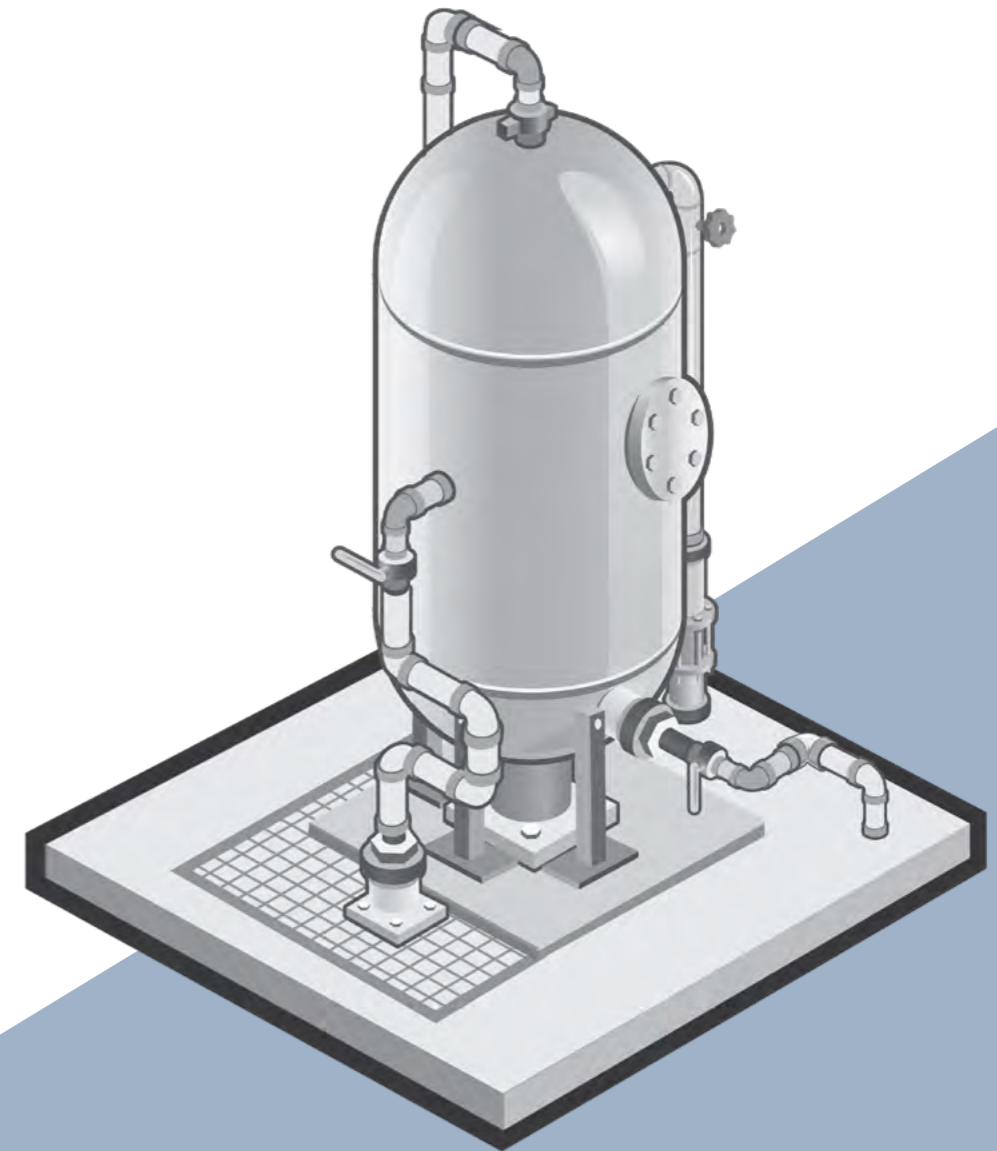
[BACK](#)[RECOMMENDED PRODUCTS](#)

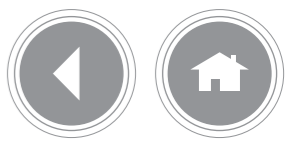

Ion Exchange Mixed Bed (IX MB)

Purification technology ideal for low TDS conditions to remove residual contaminants typically present in the ppm to ppb range.

DuPont Unique: Recognized world-leading ion exchange brands offer superior strength and quality for high performance polishing MB applications.

Benefits:

- Outstanding separation during regeneration and long resin life when using premium UPS gel/gel pair engineered for low pressure drop
- Purified steam generator blowdown can be reused as boiler feedwater, raw condensate feed, or in cooling tower water circuits

The Numbers:

- 10-20% lower ionic leakage using high stability UPS resins compared to conventional resins
- 20% higher operating capacity and 2-4x higher selectivity for sodium over typical amines when using DuPont's 16% DVB gel cation resin compared to conventional nuclear resins, allowing facilities to continue treating blowdown past the amine break

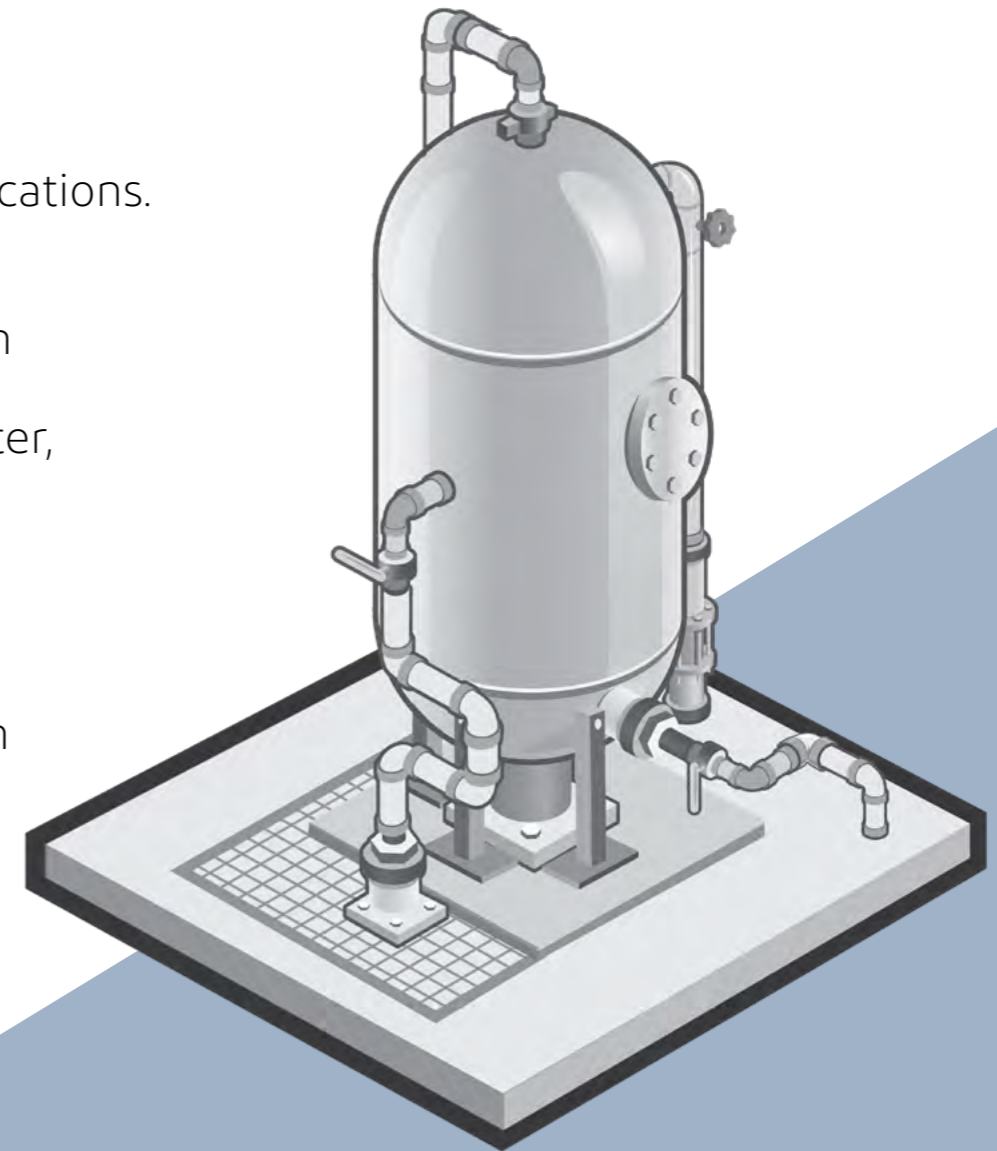
[BACK](#)[RECOMMENDED PRODUCTS](#)